



CONVECTED DRAWER WARMERS

Model CDW-3N

Designed to keep a variety of food products hot and flavor-fresh and crisp until served. These non-humidified, single cavity/single-temperature controlled units provide even, dry heat for food products that do not require humidity.

FLEXIBILITY

Available in a *freestanding* model built of rugged stainless steel with durable nylon rollers, 12-gauge stainless steel slides, and heavy-duty hardware.

The insulated top, sides and back of the Hatco Drawer Warmer provide maximum energy efficiency and the heating elements are warranted for two years.

Freestanding unit comes with a 6' (1829 mm) cord.

QUALITY

The following features assure the finest performance for years to come:

- Low velocity convected air system provides even temperature throughout the cabinet.
- Available as a freestanding model with low profile 2" (51 mm) casters (two swivel with wheel locks and two swivel) as standard.
- Digital electronic controller for easy programming and temperature accuracy.
- Tough, solid chrome handles are angled to avoid glances from passing carts.
- Narrow width fits most kitchen footprints.
- Heavy-duty drawer slides with nylon rollers.
- Each drawer fits a standard 12.75"W x 20.75"D x 2.5", 4", or 6"H (324 x 527 x 64, 102, 152 mm) food pan or 12.75"W x 20.75"D x 6"H (324 x 527 x 152 mm) perforated food pan.
- Uses 120 volts with no special wiring resulting in efficient operating costs.
- Completely insulated single cavity provides maximum energy efficiency.
- Two-year warranty on heating elements and drawer rollers and slides.



Model CDW-3N with low profile casters



Model CDW-3N with low profile casters



ANSI/NSF 4

METAL SHEATHED HEATING ELEMENTS GUARANTEED AGAINST BURNOUT AND BREAKAGE FOR TWO YEARS.

HATCO CORPORATION P.O. Box 340500 Milwaukee, WI 53234-0500 U.S.A.
 (800) 558-0607 • (414) 671-6350 • Fax (800) 543-7521 • Int'l. Fax (414) 671-3976
www.hatcocorp.com • E-mail: equipsales@hatcocorp.com

Form No. CDW Spec Sheet

Printed in U.S.A.
 January 2009



CONVECTED DRAWER WARMERS

Model CDW-3N

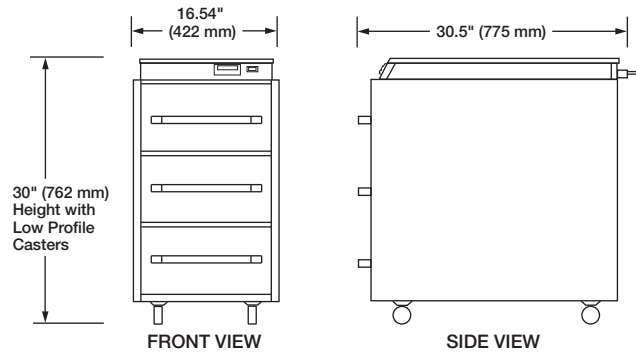

Freestanding Models

SPECIFICATIONS

Freestanding – Standard

Model [▲]	Watts	Amps [★]	No. of Drawers	Shipping Weight
CDW-3N	1015	8.5	Three	162 lbs. (73 kg)

▲ 3-drawer freestanding units are standard with low profile 2" (51 mm) casters (two swivel with wheel locks and two swivel).

★ Based on 120 volts.

DIMENSIONS

Freestanding – (With low-profile 2" (51 mm) casters).

CDW-3N: 16.54"W x 30.5"D x 30"H (422 x 775 x 762 mm).

VOLTAGE

120 volts, single phase, freestanding.

CORD LOCATION

Back of unit, top right corner.

PLUG CONFIGURATIONS

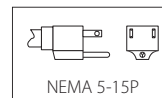

ACCESSORIES

Stainless Steel Food Pans

PRODUCT SPECS

Drawer Warmer

The Drawer Warmers shall be a Hatco Model ..., freestanding unit manufactured by the Hatco Corporation, Milwaukee, WI 53234, U.S.A.

With 24/7 parts and service assistance (U.S. and Canada only), the unit shall have ...drawer(s) and be rated at ...watts, ...amps. Freestanding model shall be equipped with a cord and plug.

The Drawer Warmer shall have a stainless steel exterior, interior, drawer slides, and assembly. Drawer rollers shall be durable nylon.

The unit shall be insulated top and sides of cabinet with digital electronic controller.