



Register Online!  
(see page 2)



## Heated Glass Shelves 黑玻璃保温板

### HGSM Model

# Installation and Operating Manual 安装及操作手册

P/N 07.04.615.00

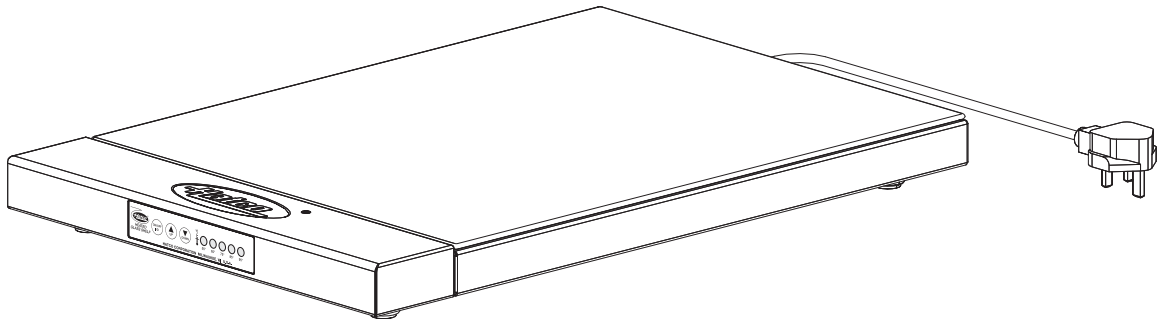

Do not operate this equipment unless you have read and understood the contents of this manual! Failure to follow the instructions contained in this manual may result in serious injury or death. This manual contains important safety information concerning the maintenance, use, and operation of this product. If you're unable to understand the contents of this manual, please bring it to the attention of your supervisor. Keep this manual in a safe location for future reference.



请在认真阅读并理解本手册的内容后再操作本设备！不按照本手册中的说明操作可能会导致严重的人身伤亡事故。本手册中包含了有关本产品维护、使用和操作的重要安全事项。如果您不理解本手册的内容，请将本手册交给主管人员，以提请其注意。请将本手册妥善放置，以便参照。

English = p 2

中文 = 第 10 页

<b>Important Owner Information</b> .....	<b>2</b>	<b>Operation</b> .....	<b>6</b>
<b>Introduction</b> .....	<b>2</b>	General .....	<b>6</b>
<b>Important Safety Information</b> .....	<b>3</b>	<b>Maintenance</b> .....	<b>7</b>
<b>Model Description</b> .....	<b>4</b>	General .....	<b>7</b>
<b>Model Designation</b> .....	<b>4</b>	Daily Cleaning .....	<b>7</b>
<b>Specifications</b> .....	<b>4</b>	Cleaning Sugary/Sticky Spills .....	<b>7</b>
Plug Configurations .....	<b>4</b>	Cleaning Burned-On Residue .....	<b>7</b>
Electrical Rating Chart.....	<b>4</b>	Cleaning Metal Marks and Scratches .....	<b>7</b>
Dimensions .....	<b>5</b>	<b>Troubleshooting Guide</b> .....	<b>8</b>
<b>Installation</b> .....	<b>5</b>	<b>International Limited Warranty</b> .....	<b>9</b>
General.....	<b>5</b>	<b>Service Information</b> .....	<b>9</b>

**IMPORTANT OWNER INFORMATION**

Record the model number, serial number (specification label located on the bottom of the unit), voltage, and purchase date of the unit in the spaces below. Please have this information available when calling Hatco for service assistance.

Model No. \_\_\_\_\_

Serial No. \_\_\_\_\_

Voltage \_\_\_\_\_

Date of Purchase \_\_\_\_\_

Business Hours: 9:00 AM to 6:00 PM (Beijing Time)

Monday through Friday

Telephone: (0512) 6732-5091

E-mail: infocn@hatcocorp.com

Fax: (0512) 6732-5092

Additional information can be found by visiting our web sites: [www.hatcocorp.com](http://www.hatcocorp.com) or [www.hatcocorp.cn](http://www.hatcocorp.cn)

**Register your unit!**

Completing online warranty registration will prevent delay in obtaining warranty coverage. Access the Hatco website at [www.hatcocorp.com](http://www.hatcocorp.com), select the *Parts & Service* pull-down menu, and click on "Warranty Registration".

**INTRODUCTION**

The Hatco Heated Glass Shelf is a portable heated shelf that is designed to hold food hot safely while blending into the surrounding décor. It will keep food at proper serving temperatures without affecting quality. These units feature a thermostatically-controlled heated glass base that extends food holding times.

The Heated Glass Shelf is a product of extensive research and field testing. The materials used were selected for maximum durability, attractive appearance, and optimum performance. Every unit is inspected and tested thoroughly prior to shipment.

This manual provides the installation, safety, and operating instructions for the Heated Glass Shelf. Hatco recommends all installation, operating, and safety instructions appearing in this manual be read prior to installation or operation of a unit.

Safety information that appears in this manual is identified by the following signal word panels:



**WARNING** indicates a hazardous situation which, if not avoided, could result in death or serious injury.



**CAUTION** indicates a hazardous situation which, if not avoided, could result in minor or moderate injury.



**NOTICE** is used to address practices not related to personal injury.



Read the following important safety information before using this equipment to avoid serious injury or death and to avoid damage to equipment or property.

**WARNING**

**ELECTRIC SHOCK HAZARD:**

- Plug unit into a properly grounded electrical receptacle of the correct voltage, size, and plug configuration. If plug and receptacle do not match, contact a qualified electrician to determine and install proper voltage and size electrical receptacle.
- Turn OFF power switch, unplug power cord, and allow unit to cool before performing any cleaning, adjustments, or maintenance.
- DO NOT submerge or saturate with water. Unit is not waterproof. Do not operate if unit has been submerged or saturated with water.
- This unit is not “jet-proof” construction. Do not use jet-clean spray to clean this unit.
- Unit is not weatherproof. Locate unit indoors where ambient air temperature is a minimum of 21°C (70°F).
- Do not pull unit by power cord.
- Discontinue use if power cord is frayed or worn.
- Do not attempt to repair or replace a damaged power cord. The cord must be replaced by Hatco, an Authorized Hatco Service Agent, or a person with similar qualifications.
- Use only Genuine Hatco Replacement Parts when service is required. Failure to use Genuine Hatco Replacement Parts will void all warranties and may subject operators of the equipment to hazardous electrical voltage, resulting in electrical shock or burn. Genuine Hatco Replacement Parts are specified to operate safely in the environments in which they are used. Some aftermarket or generic replacement parts do not have the characteristics that will allow them to operate safely in Hatco equipment.

**FIRE HAZARD:** Locate unit a minimum of 25 mm (1”) from combustible walls and materials. If safe distances are not maintained, combustion or discoloration could occur.

Make sure food product has been heated to the proper food-safe temperature before placing on the unit. Failure to heat food product properly may result in serious health risks. This unit is for holding preheated food product only.

This unit has no “user-serviceable” parts. If service is required on this unit, contact an Authorized Hatco Service Agent or contact the Hatco Service Department at (0512) 6732-5091; fax (0512) 6732-5092.

**WARNING**

Make sure all operators have been instructed on the safe and proper use of the unit.

This unit is not intended for use by children or persons with reduced physical, sensory, or mental capabilities. Ensure proper supervision of children and keep them away from the unit.

**CAUTION**

**BURN HAZARD:** Some exterior surfaces on unit will get hot. Use caution when touching these areas.

Locate unit at the proper counter height in an area that is convenient for use. The location should be level to prevent the unit or its contents from falling accidentally and strong enough to support the weight of the unit and contents.

Pitting or indentation in the glass surface may occur from sugary spills. If pitting or indentation occurs, the glass surface must be replaced. To prevent further damage and possible injury from broken glass, stop using unit immediately and contact an Authorized Hatco Service Agent.

**NOTICE**

DO NOT turn on unit until it has been cleaned thoroughly. Ceramic glass surface must be clear of debris to prevent burn-on.

Do not lay unit on the side with the control panel or damage to the unit could occur.

Do not slide pans across glass surface, use rough-bottomed pans, or drop anything on glass surface. Scratching or breakage may occur. Damage to glass surface or breakage of glass caused by misuse is not covered under warranty.

Use only wipes, pads, and cleaners designed specifically for cleaning ceramic glass surfaces. Using other wipes, pads, or cleaners may damage ceramic glass surface.

# MODEL DESCRIPTION

The Hatco Heated Glass Shelf is a portable shelf that is ideal for pass through areas, buffet lines, and as a hors d'oeuvre display. Sanitation agency approval allows the placement of food product directly on the glass surface, if desired. Standard equipment includes a heated black ceramic glass top, an electronic controller with five temperature settings, a stainless steel base, and an attached 1829 mm (6') cord and plug.

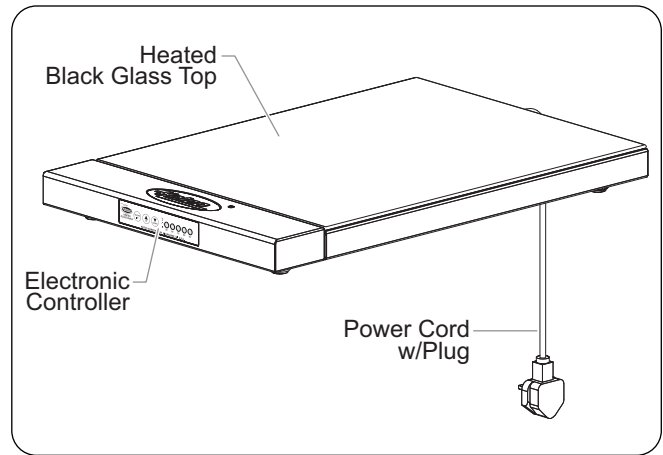

Model HGSM-4060

# MODEL DESIGNATION

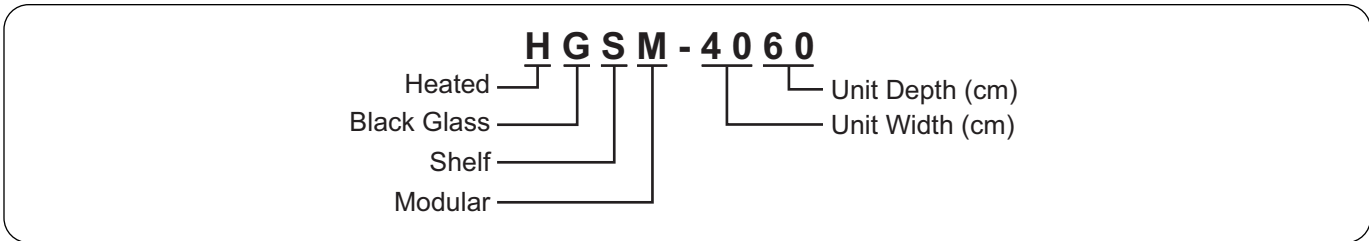

# SPECIFICATIONS

## Plug Configurations

Units are supplied from the factory with an electrical cord and plug installed. Plugs are supplied according to the application.



**ELECTRIC SHOCK HAZARD:** Plug unit into a properly grounded electrical receptacle of the correct voltage, size, and plug configuration. If plug and receptacle do not match, contact a qualified electrician to determine and install proper voltage and size electrical receptacle.

NOTE: Receptacle not supplied by Hatco.

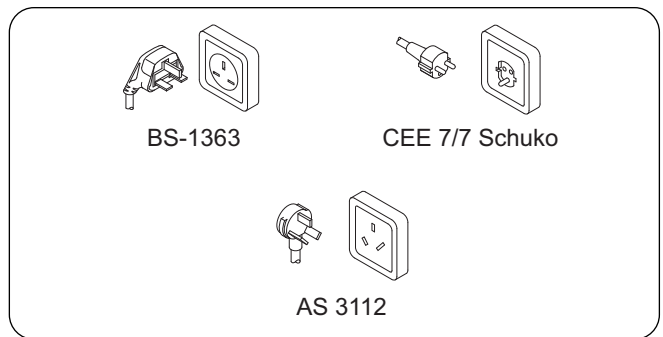

Plug Configurations

## Electrical Rating Chart

Model	Voltage	Watts	Amps	Plug Configurations	Shipping Weight
HGSM-4060	230 (CE)	300	1.3	CEE 7/7 Schuko, BS-1363 or AS 3112	8 kg (18 lbs.)

NOTE: Shipping weight includes packaging.

## Dimensions

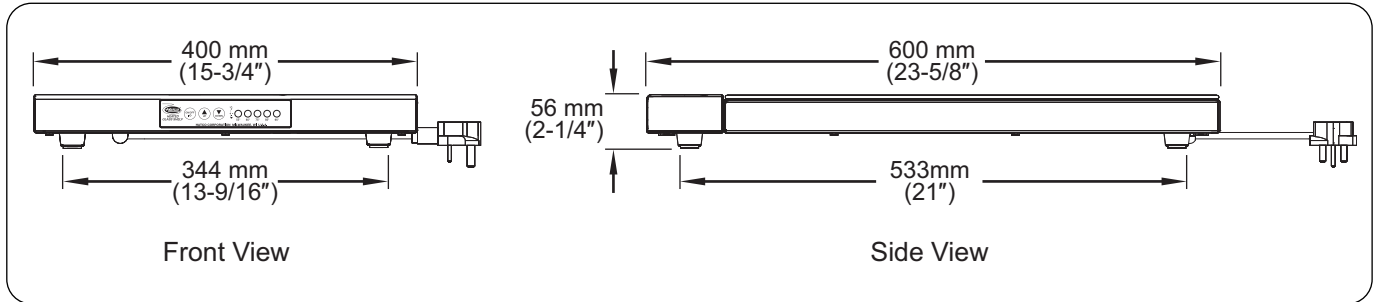

**NOTE:** The specification label is located on the bottom of the unit. See label for serial number and verification of unit electrical information.

## INSTALLATION

## General

Use the following procedure to install a Heated Glass Shelf.

**WARNING**

**ELECTRIC SHOCK HAZARD: Unit is not weatherproof. Locate unit indoors where the ambient air temperature is a minimum of 21°C (70°F).**

**FIRE HAZARD: Locate unit a minimum of 25 mm (1") from combustible walls and materials. If safe distances are not maintained, combustion or discoloration could occur.**

**CAUTION**

Locate unit at the proper counter height in an area that is convenient for use. The location should be level to prevent the unit or its contents from falling accidentally and strong enough to support the weight of the unit and contents.

Do not operate built-in models without the control box mounted properly as described in the installation instructions.

**NOTICE**

Do not lay unit on the side with the control panel or damage to the unit could occur.

1. Remove unit from box.

**NOTE:** To prevent delay in obtaining warranty coverage, complete online warranty registration. See the IMPORTANT OWNER INFORMATION section for details.

2. Remove tape and protective packaging from all surfaces of unit.
3. Place the unit in the desired location.
  - Locate the unit in an area where the ambient air temperature is constant and a minimum of 21°C (70°F). Avoid areas that may be subject to active air movements or currents (i.e., near exhaust fans/hoods and air conditioning ducts).
  - Make sure the unit is at the proper counter height in an area convenient for use.
  - Make sure the countertop is level and strong enough to support the weight of the unit and food product.
  - Make sure all the feet on the bottom of the unit are positioned securely on the countertop.

**NOTE:** Multiple Heated Glass Shelves can be placed side-by-side.

## General

Use the following procedure to turn on and operate a Heated Glass Shelf.



Read all safety messages in the **IMPORTANT SAFETY INFORMATION** section before operating this equipment.



Do not turn on unit until it has been cleaned thoroughly. Ceramic glass surface must be clear of debris to prevent burn-on.

Use only wipes, pads, and cleaners designed specifically for cleaning ceramic glass surfaces. Using other wipes, pads, or cleaners may damage ceramic glass surface.



Do not slide pans across glass surface, use rough-bottomed pans, or drop anything on glass surface. Scratching or breakage of glass caused by misuse is not covered under warranty.

## Startup

- Using an appropriate cleaning wipe or a damp cloth, clean and sanitize the glass surface of the unit. Consistent daily cleaning will keep cleanup easy as well as protect and preserve the glass surface of the unit.
- Plug the unit into a properly grounded electrical receptacle of the correct voltage, size, and plug configuration. See the SPECIFICATIONS section for details.
- Press the  key to turn on the unit.
  - The heating element will energize.
  - The indicator light for the active heat setting will illuminate.



**BURN HAZARD: Some exterior surfaces on the unit will get hot. Use caution when touching these areas.**

- Select the desired heat setting. The corresponding heat setting indicator light will illuminate to show the selected setting.
  - Press the  key to increase the heat setting.
  - Press the  key to decrease the heat setting.
- Allow the unit 30 minutes to reach operating temperature.

## Shutdown

- Press the  key to turn off the unit. The heating element and indicator light will shut off.

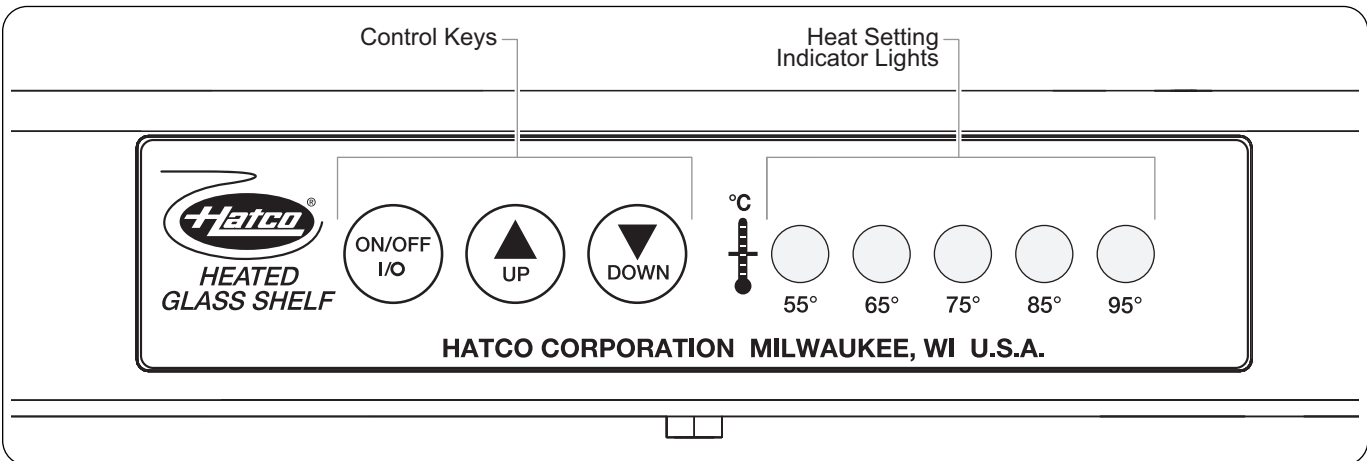

Heated Glass Shelf Control Panel

## General

Heated Glass Shelves are designed for maximum durability and performance, with minimum maintenance.



### WARNING

#### ELECTRIC SHOCK HAZARD:

- Turn OFF power switch, unplug power cord, and allow unit to cool before performing any cleaning, adjustments, or maintenance.
- DO NOT submerge or saturate with water. Unit is not waterproof. Do not operate if unit has been submerged or saturated with water.
- This unit is not “jet-proof” construction. Do not use jet-clean spray to clean this unit.
- Do not clean unit when it is energized or hot.

This unit has no “user-serviceable” parts. If service is required on this unit, contact an Authorized Hatco Service Agent or contact the Hatco Service Department at (0512) 6732-5091; fax (0512) 6732-5092.

### NOTICE

Do not turn on unit until it has been cleaned thoroughly. Ceramic glass surface must be clear of debris to prevent burn-on.

Use only wipes, pads, and cleaners designed specifically for cleaning ceramic glass surfaces. Using other wipes, pads, or cleaners may damage ceramic glass surface.

## Daily Cleaning

Consistent daily cleaning will keep cleanup easy as well as protect and preserve the glass surface. Make sure to use only wipes, pads, and cleaners designed specifically for cleaning ceramic glass surfaces.

1. Before turning on the unit each day, clean, and sanitize the glass surface using an appropriate cleaning wipe or a damp cloth.
2. At the end of each day:
  - a. Turn off the unit, unplug power cord, and allow unit to cool.
  - b. Wipe down all metal surfaces using a clean, damp, non-abrasive cloth.
  - c. Clean and sanitize the glass surface using an appropriate cleaning wipe or damp cloth. If additional cleaning is necessary, follow the “Cleaning Burned-On Residue” procedure in this section.
  - d. Wipe dry with a clean, non-abrasive cloth.

## Cleaning Sugary/Sticky Spills

To clean sugary/sticky spills, the unit should be warm while cleaning for easier removal.

1. Turn off the unit and unplug power cord. **CAUTION! Burn Hazard—Heated glass will be hot. Use caution when touching this area.**
2. While unit is still hot, wear an oven mitt and remove the bulk of the spill using paper towel.
3. Allow the unit to cool.
4. Follow the “Cleaning Burned-On Residue” procedure in this section to remove the remainder of the spill.
5. Do not use the unit again until the spill has been cleaned completely.



### CAUTION

Pitting or indentation in the glass surface may occur from sugary spills. If pitting or indentation occurs, the glass surface must be replaced. To prevent further damage and possible injury from broken glass, stop using unit immediately and contact an Authorized Hatco Service Agent.

## Cleaning Burned-On Residue

To clean burned-on residue, the use of ceramic glass cleaner may be necessary.

1. Turn off the unit, unplug power cord, and allow unit to cool.
2. Spread a few drops of ceramic glass cleaner onto the residue area.
3. Using an appropriate cleaning wipe, rub the residue area while applying pressure as needed.
4. If residue remains, repeat the steps above as needed.
5. After all residue has been removed, polish the entire glass surface using the ceramic glass cleaner and paper towel.

## Cleaning Metal Marks and Scratches

Metal marks and scratches from pans usually can be removed. Be careful when placing pans onto the glass surface. To avoid metal marks and scratches, do not slide pans across the glass surface.

1. Turn off the unit, unplug power cord, and allow unit to cool.
2. Spread a few drops of ceramic glass cleaner onto the marked area.
3. Using an appropriate cleaning wipe, rub the marked area while applying pressure as needed.
4. If metal marks and scratches remain, repeat the steps above as needed.

*NOTE: Check the bottom of all pans for roughness that could scratch the glass surface.*



*NOTE: Damage caused by sugary/sticky spills or rough pan bottoms is not covered under warranty.*



This unit must be serviced by qualified personnel only. Service by unqualified personnel may lead to electric shock or burn.



**ELECTRIC SHOCK HAZARD:** Turn OFF power switch, unplug power cord, and allow unit to cool before performing any cleaning, adjustments, or maintenance.

Symptom	Probable Cause	Corrective Action
Unit too hot.	Heat setting too high.	Press the  key on the control panel to decrease the heat setting.
	Unit plugged into an incorrect power supply.	Verify with qualified personnel that power supply matches unit specification.
Unit not hot enough.	Heat setting too low.	Press the  key on the control panel to increase the heat setting.
	Location of unit is susceptible to air currents (air conditioning ducts or exhaust fans).	Block air currents or relocate unit.
Unit not working at all.	Unit not plugged in.	Plug unit into proper power supply.
	Unit not turned on.	Press the  key on the control panel to turn on the unit.
	Control panel/temperature control not functioning.	Contact Authorized Service Agent or Hatco for assistance.
	Heating element is burned out.	Contact Authorized Service Agent or Hatco for assistance.



**1. PRODUCT WARRANTY**

Hatco warrants the products that it manufactures (the "Products") to be free from defects in materials and workmanship, under normal use and service, for a period of one (1) year from the date of purchase when installed and maintained in accordance with Hatco's written instructions or 18 months from the date of shipment from Hatco. Buyer must establish the Product's purchase date by registering the Product with Hatco or by other means satisfactory to Hatco in its sole discretion.

Hatco warrants the following Product components to be free from defects in materials and workmanship from the date of purchase (subject to the foregoing conditions) for the period(s) of time and on the conditions listed below:

**a) Two (2) Year Parts Warranty:**

Conveyor Toaster Elements (metal sheathed)  
 Drawer Warmer Elements (metal sheathed)  
 Drawer Warmer Drawer Rollers and Slides  
 Strip Heater Elements (metal sheathed)  
 Display Warmer Elements (metal sheathed air heating)  
 Holding Cabinet Elements (metal sheathed air heating)  
 Heated Well Elements — HWB Series (metal sheathed)

**b) One (1) Year Parts PLUS Four (4) Years Parts Warranty on pro-rated terms that Hatco will explain at Buyer's request:**

3CS and FR Tanks

**c) Ten (10) Year Parts Warranty:**

Electric Booster Heater Tanks  
 Gas Booster Heater Tanks

**d) Ninety (90) Day Parts Warranty:**

Replacement Parts

THE FOREGOING WARRANTIES ARE EXCLUSIVE AND IN LIEU OF ANY OTHER WARRANTY, EXPRESSED OR IMPLIED, INCLUDING BUT NOT LIMITED TO ANY IMPLIED WARRANTY OF MERCHANTABILITY OR FITNESS FOR A PARTICULAR PURPOSE OR PATENT OR OTHER INTELLECTUAL PROPERTY RIGHT INFRINGEMENT. Without limiting the generality of the foregoing, SUCH WARRANTIES DO NOT COVER: Coated incandescent light bulbs, fluorescent lights, heat lamp bulbs, coated halogen light bulbs, halogen heat lamp bulbs, xenon light bulbs, LED light tubes, glass components, and fuses; Product failure in booster tank, fin tube heat exchanger, or other water heating equipment caused by liming, sediment buildup, chemical attack, or freezing; or Product misuse, tampering or misapplication, improper installation, or application of improper voltage.

**2. LIMITATION OF REMEDIES AND DAMAGES**

Hatco's liability and Buyer's exclusive remedy hereunder will be limited solely to replacement of part or Product using, at Hatco's option, new or refurbished parts or Product by Hatco or a Hatco-authorized service agency with respect to any claim made within the applicable warranty period referred to above. Hatco reserves the right to accept or reject any such claim in whole or in part. In the context of this Limited Warranty, "refurbished" means a part or Product that has been returned to its original specifications by Hatco or a Hatco-authorized service agency. Hatco will not accept the return of any Product without prior written approval from Hatco, and all such approved returns shall be made at Buyer's sole expense. HATCO WILL NOT BE LIABLE, UNDER ANY CIRCUMSTANCES, FOR CONSEQUENTIAL OR INCIDENTAL DAMAGES, INCLUDING BUT NOT LIMITED TO LABOR COSTS OR LOST PROFITS RESULTING FROM THE USE OF OR INABILITY TO USE THE PRODUCTS OR FROM THE PRODUCTS BEING INCORPORATED IN OR BECOMING A COMPONENT OF ANY OTHER PRODUCT OR GOODS.

**SERVICE INFORMATION**

The warranty on Hatco Heated Glass Shelves is for one year from date of purchase or eighteen months from date of shipping from Hatco, whichever occurs first.

If you experience a problem with a Heated Glass Shelf during the warranty period, please do the following:

**Contact Local Hatco Dealer**

When contacting the Hatco dealer for service assistance, please supply the dealer with the following information to ensure prompt processing:

- Model of unit
- Serial number (located on the side of the unit)
- Specific problem with the unit
- Date of purchase
- Name of business
- Shipping address
- Contact name and phone number

The Hatco dealer will do the following:

- Provide replacement part(s) as required
- Submit warranty claim to Hatco for processing

**Non-Warranty Problems**

If you experience a non-warranty problem that requires assistance, please contact the nearest Authorized Hatco Service Agency.

To locate the nearest Service Agency:

- call Hatco Service at (0512) 6732-5091
- e-mail Hatco at [infocn@hatcocorp.com](mailto:infocn@hatcocorp.com)

使用者重要注意事项 .....	10	操作 .....	14
简介 .....	10	总则 .....	14
重要安全事项 .....	11	维护 .....	15
型号说明 .....	12	总则 .....	15
型号命名 .....	12	日常清洁 .....	15
规格 .....	12	清理粘稠物溢漏 .....	15
插头配置 .....	12	清理烧焦残留 .....	15
电气参数表 .....	12	清理金属痕迹和划痕 .....	15
尺寸 .....	13	故障处理指南 .....	16
安装 .....	13	全球有限质保 .....	17
总则 .....	13	服务信息 .....	17

## 使用者重要注意事项

请在下列空白处记下本设备的型号、序列号、电压、和购买日期（规格标签位于产品底部）。致电 Hatco 要求服务帮助时请提供上述信息。

型号 \_\_\_\_\_  
 序列号 \_\_\_\_\_  
 电压 \_\_\_\_\_  
 购买日期 \_\_\_\_\_

工作时间： 北京时间 上午 9:00 – 下午 6:00

电话： (0512) 6732-5091

E-mail: infocn@hatcocorp.com

传真： (0512) 6732-5092

查询更多信息请访问我们的网站：[www.hatcocorp.com](http://www.hatcocorp.com)  
[www.hatcocorp.cn](http://www.hatcocorp.cn)

## 简介

赫高黑玻璃保温板专为食品保温设计，极易融入周围的装饰中。本产品能在不影响食物口味的情况下将食物维持在合适的食用温度。产品配有一个恒温控制玻璃保温底座，可以延长食品的保温时间。

赫高黑玻璃保温板是我公司经过广泛研究和大量现场测试的产品。所选材料都是耐久性极强、外表美观、性能极佳。每个产品在出厂前都要经过严密的检查和测试。

本手册提供黑玻璃保温板的安装、安全和操作说明方面的事项。赫高建议用户在安装或是操作产品前仔细阅读本手册的所有内容。

本手册中的安全信息采用以下标志表示：



**警告**

“警告”表示有危险情况，如果不加以避免，则可能导致人身伤亡。



**小心**

“小心”表示有危险情况，如果不加以避免，则可能导致轻度或中度人身伤害。



**注意**

“注意”用于提示不会涉及人身伤害的操作。

**!** 使用本设备前，请仔细阅读下列重要安全事项，以免造成严重的人身伤亡及设备或财产的损坏。

**警告**

**触电危险：**

- 请将产品插入正确接地的插座装置，该装置的电压、尺寸和插头配置都要正确。如果插头和插座不匹配，请联系专业电工来确定并安装电压和大小合适的电源插座。
- 关闭电源开关，拔下电源线，让机器冷却，然后再进行清洗、调整或维护操作。
- 不得将设备浸入水中。本设备不具备防水性能。如果设备被水浸泡，不得进行操作。
- 本产品不防水。请将产品放在室内温度高于21°C (70°F) 的环境中。
- 不得用蒸汽或使用过多的水清洁本设备。
- 本设备不具备“防喷淋”结构。请勿使用喷淋头清洁本设备。
- 请勿用电源线拖拽本设备。
- 如果电源线出现磨损，请停止使用。
- 请勿试图维修或更换损坏的电源线。电源线必须由 Hatco、Hatco 授权服务机构或具备类似资格的人负责更换。
- 维修时只能使用正宗的 Hatco 更换零部件。未使用正宗 Hatco 更换零部件会造成质保无效，并可能造成设备操作人员受到有害电压威胁，并引起触电或着火。正宗 Hatco 更换零部件可以保证使用环境下的安全生产。某些普通零部件不具备相关特性，从而无法在 Hatco 设备内安全使用。

**着火危险：** 将产品放置在离可燃墙壁和其他材料至少25毫米 (1")的地方。如果不保持安全距离，可能会引起可燃墙壁和其他材料起火或变色。

确保所有操作人员都已了解如何安全和妥善地使用本设备。

儿童或具有身体、感觉或智力残障的人不宜使用本设备。请看护好儿童，并使其远离本设备。

本设备不含“用户维修”零部件。如需维修，请联系 Hatco 授权服务机构或 Hatco 服务部门，电话 (0512) 6732-5091；传真 (0512) 6732-5092。

**小心**

**燃烧危险：** 本设备的某些外表面处温度较高。接触这些部位时请务必小心。

将本设备置于台面高度适宜、且使用方便的位置。放置位置应水平，以防止本设备或其部件以外落地，并有足够的强度支撑本设备及其部件的重量。

玻璃台面的凹痕或压痕可能是由于粘稠物溢漏。一旦出现凹痕或压痕，必须更换玻璃台面。为了防止碎玻璃造成更多损坏或伤害，请立即停止使用产品并与赫高授权服务代理联系。

**注意**

在产品完全清理干净前，请勿运行产品。陶瓷玻璃台面必须要保持清洁，以防台面上的残留物燃烧。

请勿将产品侧置（控制面板朝下），可能会对产品造成损坏。

请勿将锅体在玻璃台面上滑动，锅底材质不能过于粗糙，且不能将任何东西砸向玻璃台面。这些都可能导致台面刮伤或破损。因使用不当而导致的玻璃台面破损不在赫高的保修范围内。

请使用清洗陶瓷玻璃台面专用的擦拭巾、棉布和清洁剂，其他的擦拭巾、棉布和清洁剂可能会损坏陶瓷玻璃台面。

赫高黑玻璃保温板是一款便携设备，可用于传菜区、自助餐或开胃食物的展示。玻璃台面符合卫生机构的认证，可将食物直接放置在台面上。标准配置包括一个黑色微晶玻璃台面保温板、一个包含五个温度设定键的电子控制面板、一个钢制底座和一条长1829毫米（6'）、带插头的电源线。

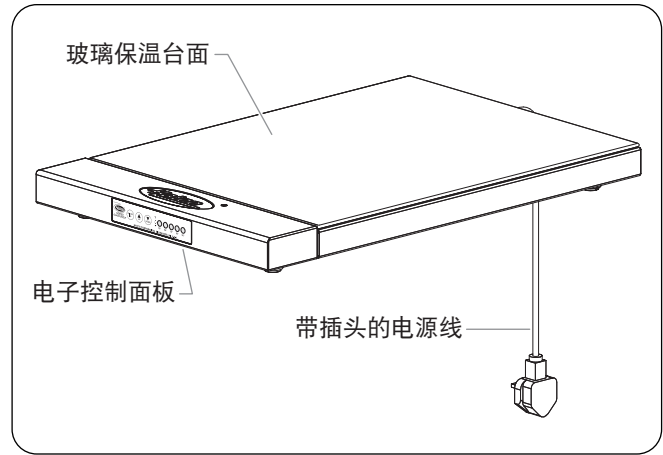

HGSM-4060型号

## 型号命名

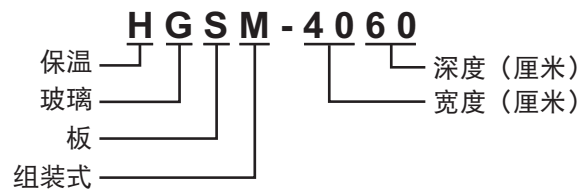

## 规格

### 插头配置

产品出厂时配有一根已装好的电源线和插头。插头是根据实际应用情况来配备的。



**触电危险：**将产品插入正确接地的插座装置，该装置的电压、尺寸和插头插座都要正确。如果插头和插座不匹配，请联系专业电工来确定并安装电压和大小合适的电源插座。

注意：插座非赫高产品。

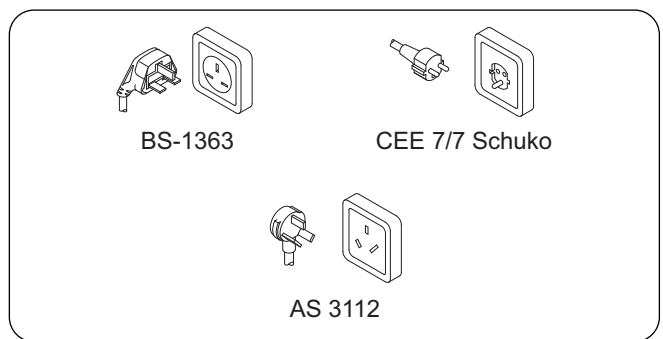

插头配置

### 电气参数表

型号	电压	功率	电流	插头配置	出厂重量
HGSM-4060	230 (CE)	300	1.3	CEE 7/7 Schuko, BS-1363 or AS 3112	8 kg (18 lbs.)

注意：出厂重量包括包装在内。

## 尺寸

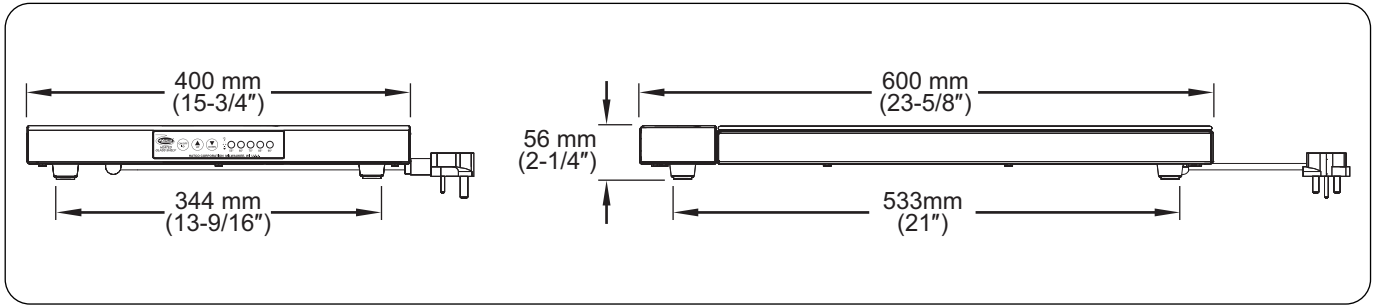

注意：产品规格标签位于产品底部。产品序列号和电气信息核实请参见规格标签。

## 安装

## 总则

请按照以下步骤来安装黑玻璃保温板。

**警告**

**触电危险：**本产品不防水。请将产品放在室内温度高于21°C (70°F)的环境中。

**着火危险：**将产品放置在离可燃墙壁和其他材料至少25毫米 (1")的地方。如果不保持安全距离，可能会引起可燃墙壁和其他材料起火或变色。

**小心**

将本设备置于台面高度适宜、且使用方便的位置。放置位置应水平，以防止本设备或其部件以外落地，并有足够的强度支撑本设备及其部件的重量。

**注意**

请勿将产品侧置（控制面板朝下），可能会对产品造成损坏。

1. 从包装箱中取出产品。

注意：为了避免质保服务发生延误，请完成网上保修登记。详情请参阅重要客户须知部分。

2. 移去产品表面所有的包装带和包装材料。

3. 将产品安装在理想位置。

- 将产品放在周围温度恒定且不低于21°C (70 ° F) 的环境中。请勿放置在空气/气流流动频繁（例如靠近排气风扇/抽油烟机 and 空调管道）的地方。
- 确保将产品放置于方便使用的适合高度台面上。
- 确保台面水平且能够承受产品和食物的重量。
- 请将产品底部的所有支脚牢牢固定在台面上。

注意：可将多个保温玻璃板并排放置。

**总则**

请按照下列步骤来运行和操作赫高黑玻璃保温板。



**警告**

操作本设备前，请仔细阅读“重要安全事项”中的所有安全说明。



**注意**

在产品完全清理干净前，请勿运行产品。陶瓷玻璃台面必须要保持清洁，以防台面上的残留物燃烧。

请使用清洗陶瓷玻璃台面专用的擦拭巾、棉布和清洁剂，其他擦拭巾、棉布和清洁剂可能会损坏陶瓷玻璃台面。

请勿将锅体在玻璃台面上滑动，锅底的材料不能过于粗糙，且不能将任何东西砸向玻璃台面。这些都可能导致台面刮伤或破损。因使用不当而导致的玻璃台面破损不在赫高的保修范围内。

**启动**

1. 用擦拭布或湿布来清洁产品的玻璃台面。持续每日清洁让台面清洁变得轻松省力并可以保护玻璃台面。
2. 请将产品插入正确接地的插座装置，该装置的电压、尺寸和插头配置都要正确。详情请参见【产品规格】部分。
3. 请按  键启动产品。
  - 加热元件开始启动。
  - 温度设定指示灯会发亮。



**小心**

**燃烧危险：**本设备的某些外表面处温度较高。接触这些部位时请务必小心。

4. 调节温度设定值。所选温度对应的温度设定指示灯会发亮
  - 要调高温度设定值，请按  键。
  - 要调低温度设定值，请按  键。
5. 让产品运行30分钟来达到工作温度。

**关闭**

1. 要关闭产品，请按  键。加热元件和指示灯都会停止运行。

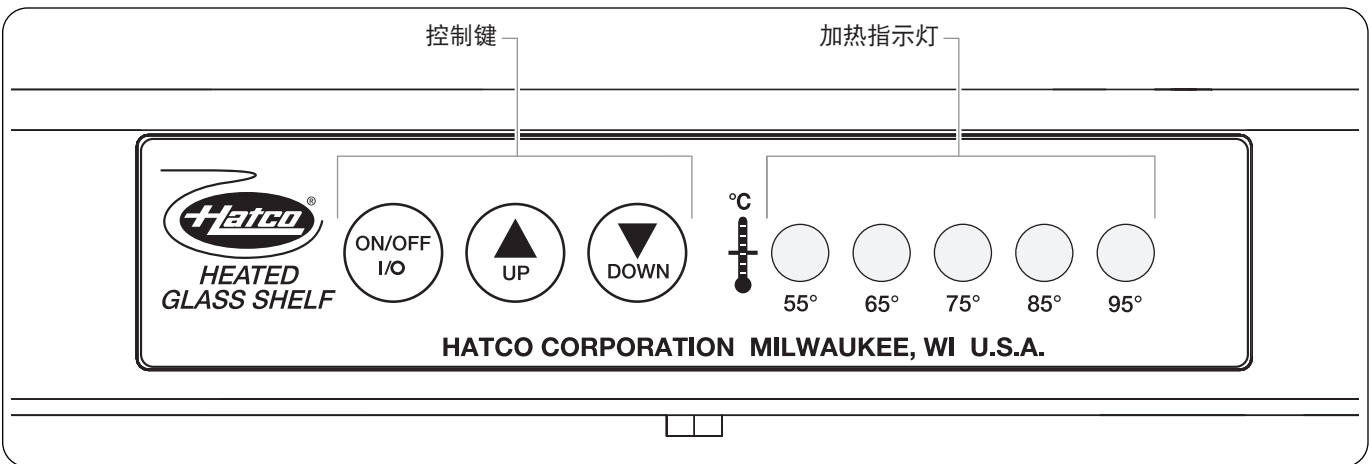

黑保温板控制面板



## 总则

赫高黑玻璃保温板具有高耐久性、产品性能卓越，极易保养。

### 警告

#### 触电危险：

- 将电源开关切换到“关”，拔去电源线，让产品冷却，然后再进行任何清洗、调试或保养。
- 不得将设备浸入水中。本设备不具备防水性能。如果设备被水浸泡，不得进行操作。
- 不得用蒸汽或使用过多的水清洁本设备。
- 本设备不具备“防喷淋”结构。请勿使用喷淋头清洁本设备。

本设备不含“用户维修”零部件。如需维修，请联系 Hatco 授权服务机构或 Hatco 服务部门，电话 (0512) 6732-5091；传真 (0512) 6732-5092。

### 注意

在产品完全清理干净前，请勿运行产品。陶瓷玻璃台面必须要保持清洁，以防台面上的残留物燃烧。

请使用清洗陶瓷玻璃台面专用的擦拭巾、棉布和清洁剂，其他的擦拭巾、棉布和清洁剂可能会损坏陶瓷玻璃台面。

## 日常清洁

持续每日清洁让台面清洁变得轻松省力并可以保护玻璃台面。请使用清洗陶瓷玻璃台面专用的擦拭巾、棉布和清洁剂。

1. 每天使用产品前，请用擦拭布或湿布来清洁产品的玻璃台面。
2. 每天使用完产品后：
  - a. 关闭设备，拔掉电源线，并让产品完全冷却。
  - b. 用干净的非腐蚀性湿抹布将所有金属表面擦净。
  - c. 用擦拭布或湿布来清洁产品的玻璃台面。若需进一步清洁，请参照本节中的“清理烧焦残留”步骤。
  - d. 用干净的非腐蚀性干抹布将玻璃台面擦净。

## 清理粘稠物溢漏

清理粘稠物溢漏时，应该让产品保持一定的温度，从而更好地清理粘稠物。

1. 关闭产品，并拔掉电源线。注意！烧伤危险——保温玻璃会很烫，触摸玻璃时要格外小心。
2. 产品若仍是热的，戴上烤箱手套，用纸巾将大部分粘稠溢漏物清理干净。
3. 让产品完全冷却。
4. 参照本节中“清洁烧焦残留”部分清除剩余溢漏物。
5. 直到溢漏物完全清理干净前，请勿使用产品。

### 小心

玻璃台面的凹痕或压痕可能是由于粘稠物遗漏。一旦出现凹痕或压痕，玻璃台面必须更换。为了防止碎玻璃造成更多损坏或伤害，请立即停止使用产品并与赫高授权服务代理联系。

## 清理烧焦残留

要清理烧焦残留，可能需要使用陶瓷玻璃清洗剂。

1. 关闭产品，拔掉电源线，让产品完全冷却。
2. 在残留物区域表面滴几滴陶瓷玻璃专用清洗剂。
3. 用擦拭布适力擦拭残留物区域。
4. 若仍有残留，必要时请重复上述步骤。
5. 所有残留物清理干净后，用陶瓷玻璃清洁剂和纸巾擦亮整个玻璃表面。

## 清理金属痕迹和划痕

锅体造成的金属痕迹和划痕，通常可以被清理。使用产品时请将锅小心放置到玻璃台面。为了避免金属痕迹和划痕，请勿将锅体在玻璃台面上滑动。

1. 关闭产品，拔掉电源线，让产品完全冷却。
2. 在划痕区域表面滴几滴陶瓷玻璃专用清洗剂。
3. 用擦拭布适力擦拭划痕区域。
4. 若仍有金属痕迹和划痕，必要时请重复上述步骤。

注意：检查所有锅底，以防其粗糙材质刮伤玻璃台面。

注意：粘稠物溢漏或粗糙锅底对产品造成的损坏不在赫高的保修范围内。





警告

本设备只能由受过培训且具备相应资格的人员负责维修。若由不具备相应资格的人员维修，则可能引起触电或着火。



警告

触电危险：将电源开关切换到“关”，拔去电源线，让产品冷却，然后再进行任何维护、调试或清洗。

症状	可能原因	纠正措施
产品太热。	设定温度太高。	按下控制面板上的  键将设定温度调低。
	产品未连接到正确电源。	让专业电工来检查电源是否与产品规格一致。
产品不够热。	设定温度太低。	按下控制面板上的  键将设定温度调高。
	产品位置周围（空调管道或排气扇附近）有过量的空气流动。	阻止空气流动或移动产品位置。
产品不能运行。	产品未连接电源。	将产品连接至正确电源。
	未开始运行产品。	按下控制面板上的  键启动产品。
	控制面板/温度控制有问题。	联系赫高或其授权代理。
	加热元件烧坏了。	联系赫高或其授权代理。



## 1. 产品质保

赫高保证其生产的产品（下称“本产品”）不存在材料和工艺缺陷，在按照赫高的说明书安装和维护的情况下，自购买之日起1年内（用户必须书面且保养）或自赫高出厂之日起18个月内，设备可以保证正常工作。客户必须通过在赫高的官网上完成本产品的注册来确定产品的购买日期，或是经由赫高判断进而认可的其他方式。

赫高保证在下述时间内及条件下，下列部件自购买之日起（符合上述条件）起不存在材料和工艺缺陷（条件如下）：

### a) 保修期为两（2）年的部件：

- 履带式烤面包机加热器（金属铠装）
- 保温抽屉加热器（金属铠装）
- 保温抽屉的抽屉滚轴和滑轨
- S食品保温器加热器（金属铠装）
- 保温陈列柜加热元件（金属铠装、空气加热）
- 保温柜加热元件（金属铠装、空气加热）
- 保温汤锅加热元件—HWB系列（金属铠装）

### b) 保修期为一（1）年和四（4）年的部件费用分摊由赫高视用户要求给予解释：

3CS和FR水箱

### c) 保修期为十（10）年的部件：

- 电动瞬时加热器的水箱
- 煤气瞬时加热器的水箱

### d) 保修期为九十（90）天的部件：

可更换零件

上述质保为赫高独家提供，并代替任何明示或隐含的质保，包括但不限于侵犯某个特定用途、专利或其他知识产权的适够性或实用性的银汉质保。在没有特定说明的情况下，上述质保不包括：带涂层白炽灯泡、日光灯、保温加热灯泡、带涂层卤素灯泡、卤素加热灯泡、氙气灯泡、LED光管、玻璃组件和保险丝；由于结垢、化学腐蚀或严寒造成的瞬时加热器水箱、翅片管式换热器或其他水加热设备的故障；或产品使用不当、擅自改动或误用、安装不当，或电压不正确。

## 2. 修复和损坏限制

本文所述赫高责任以及对用户的独家修复补偿义务仅限于在上述保修期内提出索赔，由赫高或赫高授权的服务机构负责更换新零件或产品或对原零件或产品进行维修。赫高有权接受或拒绝任何此类全部或部分的索赔。在此有限质保规定中，“翻新”是指本产品的部分或整机已经被赫高或赫高授权的服务代理机构修复至原有的产品规格。未经赫高事先书面批准，赫高不接受任何产品的退回，经过赫高同意的产品退回，其相关费用均由用户独自承担。在任何情况下，对于因故或意外而引起的损失，包括但不限于人工费用，或因产品的使用，或不会用，或产品隶属或成为其他产品的一部分而造成的利润损失，赫高将不予负责。

## 服务信息

本产品自购买之日一年或自赫高提货之日起十八个月之内（以较早日期为准）免费保修。

在保修期内，保温板若发生下列情形，请做如下处理：

### 联系本地 Hatco 经销商

当联系 Hatco 经销商提供服务帮助时，请将以下信息提供给经销商，以确保得到及时处理：

- 设备型号
- 序列号（位于产品底部）
- 设备的具体问题
- 购买日期
- 企业名称
- 发运地址
- 联系人姓名和电话号码

Hatco 经销商会为您：

- 提供所需要的更换零部件
- 向 Hatco 提出质保索赔以供处理

### 非质保期故障

如果您的设备在非质保期内出现故障需要提供帮助，请联系就近的HATCO授权服务机构。

查找就近的HATCO授权服务机构：

- 打(0512) 6732-5091电话联系HATCO服务部门。
- 发邮件到info@hatcocorp.com联系HATCO服务部门。

---

---

---

---

---

---

---

---

---

---

---

---

---

---

---

---

---

---

---

---

---

---

---



**Register your unit online!**

See IMPORTANT OWNER INFORMATION  
section for details.

HATCO CORPORATION  
P.O. Box 340500  
Milwaukee, WI 53234-0500 U.S.A.  
Telephone (414) 671-6350  
International Fax (414) 671-3976  
partsandservice@hatcocorp.com  
www.hatcocorp.com

HATCO CORPORATION  
ASIA HEADQUARTERS  
Unit 101, Premier Center, 20 Cheung Shun Street  
Cheung Sha Wan, Kowloon, H.K.  
Telephone (852) 2991-4121  
Fax (852) 2991-4181  
hongkong@hatcocorp.com