



GLO-RAY®

Designer Infrared Foodwarmers

GR2A & GR2AH Series

Installation & Operating Manual

I&W # 07.05.115.00

This manual contains important safety information concerning the maintenance, use and operation of this product. Failure to follow the instructions contained in this manual may result in serious injury. If you are unable to understand the contents of this manual, please bring it to the attention of your supervisor. Do not operate this equipment unless you have read and understood the contents of this manual.

Este manual contiene importante información sobre seguridad concerniente al mantenimiento, uso y operación de este producto. Cualquier falla en el seguimiento de las instrucciones contenidas en este manual puede resultar en un serio daño. Si usted no puede entender el contenido de este manual por favor pregunte a su supervisor. No opere este equipo al menos que haya leído y comprendido el contenido de este manual.

CONTENTS

Important Owner Information	i	Dimensions.....	11
Introduction	i	Installation	12
Important Safety Instructions	1	Location	12
Model Descriptions	2	All Models	13
All Models	2	Assembly.....	13
GR2A and GR2AH Models	2	RMB (Remote Control Box).....	14
Model Designations	2	Electrical Requirements	14
Specifications	3	Breath Protector (Optional).....	14
Electrical Rating Chart-GR2A Models	3	Operation	14
Electrical Rating Chart-GR2AH Models	4	All Models	14
Electrical Rating Chart-GR2AL Models	5	Maintenance	15
Electrical Rating Chart-GR2AHL Models.....	6	Cleaning	15
Electrical Rating Chart-GR2A-XXD Models.....	7	Display Light Bulb Replacement.....	15
Electrical Rating Chart-GR2AH-XXD Models.....	8	Hatco Limited Warranty	16
Electrical Rating Chart-GR2AL-XXD	9	Authorized Parts Distributors	Back Cover
Electrical Rating Chart-GR2AHL-XXD Models .	10		

IMPORTANT OWNER INFORMATION

Record the model number, serial number (identification plate is located on the inside of the leg near the top), voltage and purchase date of your *Designer* Infrared Foodwarmers in the spaces below. Please have this information available when calling Hatco for service assistance.

Model No. _____

Serial No. _____

Voltage _____

Date of Purchase _____

Business Hours: 8:00 a.m. to 5:00 p.m.
Central Standard Time

(Summer Hours: June to September -
8:00 a.m. to 5:00 p.m. C.D.T.
Monday through Thursday
8:00 a.m. to 2:30 p.m. C.D.T. Friday)



Telephone: (800) 558-0607; (414) 671-6350

Fax: (800) 690-2966 (Parts & Service)
(414) 671-3976 (International)

INTRODUCTION

Hatco Glo-Ray® *Designer* Infrared Foodwarmers ensure maximum holding and minimize the risk of food-borne illness. Optimum safety and quality is the result of food held at the proper serving temperatures, using Glo-Ray's pre-focused heat patterns. The pre-focused heat pattern prevents foods from being over-cooked in the middle and cooling off around the edges by concentrating higher temperatures to the outer edges of holding surfaces where heat loss is the greatest. Utilizing specially designed reflectors to direct the heat from the element, Glo-Ray safely maintains peak serving temperatures longer, without continuing to cook the food.

The Glo-Ray *Designer* Foodwarmers are available with or without shatter-resistant incandescent lights to illuminate the warming area. These bulbs have a special coating that guards against injury and food contamination in the event of breakage.







This manual provides the installation, safety and operating instructions for the Glo-Ray *Designer* Infrared Foodwarmers. We recommend all installation, operating and safety instructions appearing in this manual be read prior to installation or operation of your Hatco Foodwarmer. Safety instructions that appear in this manual after a warning symbol  and the words **WARNING** or **CAUTION** printed in bold face are very important.  **WARNING** means there is the possibility of serious injury or death to yourself or others.  **CAUTION** means there is the possibility of minor or moderate injury. **CAUTION** *without the symbol* signifies the possibility of equipment or property damage only.

Hatco Foodwarmers are a product of extensive research and field testing. The materials used were selected for maximum durability, attractive appearance and optimum performance. Every unit is thoroughly inspected and tested prior to shipment.







IMPORTANT SAFETY INSTRUCTIONS

IMPORTANT! Read the following important safety instructions to avoid personal injury or death, and to avoid damage to the equipment or property.

WARNINGS

-  1. To avoid any injury, turn the power off to the unit and allow to cool before performing any maintenance.
-  2. Only light bulbs which meet or exceed N.S.F. standards, specifically designed for food holding areas must be used. Breakage of light bulbs not specially coated could result in personal injury and/or food contamination.
-  3. For safe and proper operation, the unit must be located a reasonable distance from combustible walls and materials. If safe distances are not maintained, discoloration or combustion could occur.
-  4. Do not install standard wattage foodwarmer (GR2A & GR2AL Series) less than 17" (43 cm) above nonmetallic surface. Do not install high wattage foodwarmer (GR2AH Series) less than 20" (51 cm) above nonmetallic surface. Do not install high wattage foodwarmer (GR2AHL Series) less than 22" (56 cm) above nonmetallic surface. Do not install standard wattage, dual foodwarmer (GR2A-XXD Series) less than 27" (69 cm) above nonmetallic surface. Do not install high wattage, dual foodwarmer (GR2AH-XXD & GR2AHL-XXD Series) less than 32" (81 cm) above nonmetallic surface. Install all *Designer* foodwarmers so there is a minimum distance of 6" (15 cm) from a nonmetallic wall or adjacent surface.
-  5. If service is required on this unit, contact your Authorized Hatco Service Agent, or contact the Hatco Service Department at 800-558-0607 or 414-671-6350; fax 800-690-2966 or International fax 414-671-3976.
-  6. This product has no "user" serviceable parts. To avoid damage to the unit or injury to personnel, use only Authorized Hatco Service Agents and Genuine Hatco Parts when service is required.
-  7. Genuine Hatco Replacement Parts are specified to operate safely in the environments in which they are used. Some aftermarket or generic replacement parts do not have the characteristics that will allow them to operate safely in Hatco equipment. It is essential to use Hatco Replacement Parts when repairing Hatco equipment. Failure to use Hatco Replacement Parts may subject operators of the equipment to hazardous electrical voltage, resulting in electrical shock or burn.

CAUTIONS

-  1. Some exterior surfaces on the unit will get hot. Use caution when touching these areas to avoid injury.
-  2. Locate the unit at the proper counter height, in an area that is convenient for use. The location should be level to prevent the unit or its contents from accidentally falling, and strong enough to support the weight of the unit and food.
-  3. Do not submerge unit in water.
-  4. Do not add a decorative soffit to hide a pass-through mounted Glo-Ray Foodwarmer.
-  5. All electrical connections must be in accordance with local electrical codes and any other applicable codes. Connections should be made by a qualified, licensed electrician.
-  6. Foodwarmers with incandescent lights that require a circuit breaker larger than 20 amps must have a separate circuit breaker for the incandescent lights that is 20 amps or less.

CAUTIONS

1. Use only non-abrasive cleaners. Abrasive cleaners could scratch the finish of your unit marring its appearance and making it susceptible to soil accumulation.
2. The remote control box (RMB) must be installed outside of the heat zone.
3. Damage to countertop material such as Corian® and similar products caused by heat generated from Hatco equipment is not covered under the Hatco warranty. Contact the manufacturer of the base material for application information.

MODEL DESCRIPTIONS

ALL MODELS

The Glo-Ray *Designer* Infrared Foodwarmers are ideal for holding hot food on pass-through holding areas and waitress pick-up stations. All *Designer* models are constructed of aluminum.

The advanced Glo-Ray Dual Models allow side-by-side mounting of two or more aluminum warmers, to provide a wider holding area, with a 3" or 6" (8 or 15 cm) spacer available.

For self-serve applications, models may be equipped with optional easy-to-clean acrylic breath protectors, single- or double-sided mounting.

GR2A AND GR2AH MODELS

The Glo-Ray *Designer* available in sizes from 22" to 88" (56 to 224 cm) in length with *Designer* color inset panels. The Glo-Ray *Designer* Foodwarmers include prefocused infrared top heat and can be ordered with incandescent display lights and optional easy-to-install breath protectors.

MODEL DESIGNATIONS

Units are available in aluminum gray with *Designer* inset panel colors or, an all black unit.

GR2A Series:

Glo-Ray *Designer* Aluminum Standard Wattage

GR2AL Series:

Glo-Ray *Designer* Aluminum Standard Wattage with Lights

GR2A-XXD Series:

Glo-Ray *Designer* Aluminum Standard Wattage Dual

GR2AL-XXD Series

Glo-Ray *Designer* Aluminum Standard Wattage Dual with Lights.

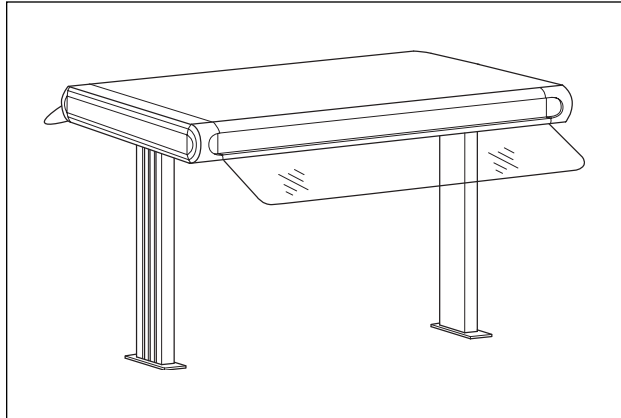

Figure 1. Glo-Ray *Designer* Foodwarmer with Display Lights and Optional Breath Protectors

GR2AH Series

Glo-Ray *Designer* Aluminum High Wattage

GR2AHL Series

Glo-Ray *Designer* Aluminum High Wattage with Lights

GR2AH-XXD Series

Glo-Ray *Designer* Aluminum High Wattage Dual

GR2AHL-XXD Series

Glo-Ray *Designer* Aluminum High Wattage Dual with Lights.

NOTE: XX denotes the heat zone width dimensions; example GR2AH-24D.

SPECIFICATIONS

ELECTRICAL RATING CHART – GR2A MODELS

Model	Voltage	Watts	Amps	Shipping Weight
GR2A-18	120	250	2.1	36 lbs. (16 kg)
	208	250	1.2	36 lbs. (16 kg)
	240	250	1.0	36 lbs. (16 kg)
GR2A-24	120	350	2.9	38 lbs. (17 kg)
	208	350	1.7	38 lbs. (17 kg)
	240	350	1.5	38 lbs. (17 kg)
GR2A-30	120	450	3.8	42 lbs. (19 kg)
	208	450	2.2	42 lbs. (19 kg)
	240	450	1.9	42 lbs. (19 kg)
GR2A-36	120	575	4.8	46 lbs. (21 kg)
	208	575	2.8	46 lbs. (21 kg)
	240	575	2.4	46 lbs. (21 kg)
GR2A-42	120	675	5.6	54 lbs. (25 kg)
	208	675	3.3	54 lbs. (25 kg)
	240	675	2.8	54 lbs. (25 kg)
GR2A-48	120	800	6.7	64 lbs. (29 kg)
	208	800	3.9	64 lbs. (29 kg)
	240	800	3.3	64 lbs. (29 kg)
GR2A-54	120	925	7.7	74 lbs. (34 kg)
	208	925	4.5	74 lbs. (34 kg)
	240	925	3.9	74 lbs. (34 kg)
GR2A-60	120	1050	8.8	82 lbs. (37 kg)
	208	1050	5.1	82 lbs. (37 kg)
	240	1050	4.4	82 lbs. (37 kg)
GR2A-66	120	1160	9.7	91 lbs. (41 kg)
	208	1160	5.6	91 lbs. (41 kg)
	240	1160	4.8	91 lbs. (41 kg)
GR2A-72	120	1275	10.6	100 lbs. (45 kg)
	208	1275	6.1	100 lbs. (45 kg)
	240	1275	5.3	100 lbs. (45 kg)
GR2A-84	120	1500	12.5	120 lbs. (54 kg)
	208	1500	7.2	120 lbs. (54 kg)
	240	1500	6.3	120 lbs. (54 kg)

SPECIFICATIONS

ELECTRICAL RATING CHART – GR2AH MODELS

Model	Voltage	Watts	Amps	Shipping Weights
GR2AH-18	120	350	2.9	36 lbs. (16 kg)
	208	350	1.7	36 lbs. (16 kg)
	240	350	1.5	36 lbs. (16 kg)
GR2AH-24	120	500	4.2	38 lbs. (17 kg)
	208	500	2.4	38 lbs. (17 kg)
	240	500	2.1	38 lbs. (17 kg)
GR2AH-30	120	660	5.5	42 lbs. (19 kg)
	208	660	3.2	42 lbs. (19 kg)
	240	660	2.8	42 lbs. (19 kg)
GR2AH-36	120	800	6.7	46 lbs. (21 kg)
	208	800	3.9	46 lbs. (21 kg)
	240	800	3.3	46 lbs. (21 kg)
GR2AH-42	120	950	7.9	54 lbs. (25 kg)
	208	950	4.6	54 lbs. (25 kg)
	240	950	4.0	54 lbs. (25 kg)
GR2AH-48	120	1100	9.2	64 lbs. (29 kg)
	208	1100	5.3	64 lbs. (29 kg)
	240	1100	4.6	64 lbs. (29 kg)
GR2AH-54	120	1250	10.4	74 lbs. (34 kg)
	208	1250	6.0	74 lbs. (34 kg)
	240	1250	5.2	74 lbs. (34 kg)
GR2AH-60	120	1400	11.7	82 lbs. (37 kg)
	208	1400	6.7	82 lbs. (37 kg)
	240	1400	5.8	82 lbs. (37 kg)
GR2AH-66	120	1560	13.0	91 lbs. (41 kg)
	208	1560	7.5	91 lbs. (41 kg)
	240	1560	6.5	91 lbs. (41 kg)
GR2AH-72	120	1725	14.4	100 lbs. (45 kg)
	208	1725	8.3	100 lbs. (45 kg)
	240	1725	7.2	100 lbs. (45 kg)
GR2AH-84	120†	1900	15.8	120 lbs. (54 kg)
	208	2050	9.9	120 lbs. (54 kg)
	240	2050	8.5	120 lbs. (54 kg)

† GR2AH-84 series units, 120 volt, contain tandem heating elements individually controlled.

SPECIFICATIONS

ELECTRICAL RATING CHART – GR2AL MODELS

Model	Voltage	Watts	Amps		Shipping Weight
			Heating Circuit	Light Circuit	
GR2AL-18	120	370	2.1	1.0	39 lbs. (18 kg)
	120/208*	370	1.2	1.0	39 lbs. (18 kg)
	120/240*	370	1.0	1.0	39 lbs. (18 kg)
GR2AL-24	120	470	2.9	1.0	41 lbs. (19 kg)
	120/208*	470	1.7	1.0	41 lbs. (19 kg)
	120/240*	470	1.5	1.0	41 lbs. (19 kg)
GR2AL-30	120	570	3.8	1.0	45 lbs. (20 kg)
	120/208*	570	2.8	1.0	45 lbs. (20 kg)
	120/240*	570	2.4	1.0	45 lbs. (20 kg)
GR2AL-36	120	755	4.8	1.5	50 lbs. (23 kg)
	120/208*	755	2.8	1.5	50 lbs. (23 kg)
	120/240*	755	2.4	1.5	50 lbs. (23 kg)
GR2AL-42	120	855	5.6	1.5	59 lbs. (27 kg)
	120/208*	855	4.6	1.5	59 lbs. (27 kg)
	120/240*	855	4.0	1.5	59 lbs. (27 kg)
GR2AL-48	120	1040	6.7	2.0	70 lbs. (32 kg)
	120/208*	1040	5.3	2.0	70 lbs. (32 kg)
	120/240*	1040	4.6	2.0	70 lbs. (32 kg)
GR2AL-54	120	1165	7.7	2.0	80 lbs. (36 kg)
	120/208*	1165	4.5	2.0	80 lbs. (36 kg)
	120/240*	1165	3.9	2.0	80 lbs. (36 kg)
GR2AL-60	120	1350	8.8	2.5	89 lbs. (40 kg)
	120/208*	1350	5.1	2.5	89 lbs. (40 kg)
	120/240*	1350	4.4	2.5	89 lbs. (40 kg)
GR2AL-66	120	1460	9.7	2.5	99 lbs. (45 kg)
	120/208*	1460	5.6	2.5	99 lbs. (45 kg)
	120/240*	1460	4.8	2.5	99 lbs. (45 kg)
GR2AL-72	120	1635	10.7	3.0	108 lbs. (49 kg)
	120/208*	1635	6.1	3.0	108 lbs. (49 kg)
	120/240*	1635	5.3	3.0	108 lbs. (49 kg)
GR2AL-84	120	1860	12.5	3.0	129 lbs. (59 kg)
	120/208*	1860	7.2	3.0	129 lbs. (59 kg)
	120/240*	1860	6.3	3.0	129 lbs. (59 kg)

* Units rated for 120/208 or 120/240 volt are manufactured with a 120 volt circuit for the incandescent lights and a 208 or 240 volt circuit for the heating element(s).

SPECIFICATIONS

ELECTRICAL RATING CHART – GR2AHL MODELS

Model	Voltage	Watts	Amps		Shipping Weight
			Heating Circuit	Light Circuit	
GR2AHL-18	120	470	2.9	1.0	39 lbs. (18 kg)
	120/208*	470	1.7	1.0	39 lbs. (18 kg)
	120/240*	470	1.5	1.0	39 lbs. (18 kg)
GR2AHL-24	120	620	4.2	1.0	41 lbs. (19 kg)
	120/208*	620	2.4	1.0	41 lbs. (19 kg)
	120/240*	620	2.1	1.0	41 lbs. (19 kg)
GR2AHL-30	120	780	5.5	1.0	45 lbs. (20 kg)
	120/208*	780	3.2	1.0	45 lbs. (20 kg)
	120/240*	780	2.8	1.0	45 lbs. (20 kg)
GR2AHL-36	120	980	6.7	1.5	50 lbs. (23 kg)
	120/208*	980	3.9	1.5	50 lbs. (23 kg)
	120/240*	980	3.3	1.5	50 lbs. (23 kg)
GR2AHL-42	120	1130	7.9	1.5	59 lbs. (27 kg)
	120/208*	1130	4.6	1.5	59 lbs. (27 kg)
	120/240*	1130	4.0	1.5	59 lbs. (27 kg)
GR2AHL-48	120	1340	9.2	2.0	70 lbs. (32 kg)
	120/208*	1340	5.3	2.0	70 lbs. (32 kg)
	120/240*	1340	4.6	2.0	70 lbs. (32 kg)
GR2AHL-54	120	1490	10.4	2.0	80 lbs. (36 kg)
	120/208*	1490	6.0	2.0	80 lbs. (36 kg)
	120/240*	1490	5.2	2.0	80 lbs. (36 kg)
GR2AHL-60	120	1700	11.7	2.5	89 lbs. (40 kg)
	120/208*	1700	6.7	2.5	89 lbs. (40 kg)
	120/240*	1700	5.8	2.5	89 lbs. (40 kg)
GR2AHL-66	120	1860	13.0	2.5	99 lbs. (45 kg)
	120/208*	1860	7.5	2.5	99 lbs. (45 kg)
	120/240*	1860	6.5	2.5	99 lbs. (45 kg)
GR2AHL-72	120•	2085	14.4	3.0	108 lbs. (49 kg)
	120/208*	2085	8.3	3.0	108 lbs. (49 kg)
	120/240*	2085	7.2	3.0	108 lbs. (49 kg)
GR2AHL-84	120†•	2320	15.8	3.5	129 lbs. (59 kg)
	120/208*	2470	9.9	3.5	129 lbs. (59 kg)
	120/240*	2470	8.5	3.5	129 lbs. (59 kg)

† GR2AHL-84 series units, 120 volt, contain tandem heating elements individually controlled.

* Units rated for 120/208 or 120/240 volt are manufactured with a 120 volt circuit for the incandescent lights and a 208 or 240 volt circuit for the heating element(s).

• Not available in Canada.

 **CAUTION**

Foodwarmers with incandescent lights that require a circuit breaker larger than 20 amps must have a separate circuit breaker for the incandescent lights that is 20 amps or less.

SPECIFICATIONS

ELECTRICAL RATING CHART – GR2A-XXD MODELS

Model	Voltage	Watts	Amps	Shipping Weight
GR2A-18D	120	500	4.2	44 lbs. (20 kg)
	208	500	2.4	44 lbs. (20 kg)
	240	500	2.1	44 lbs. (20 kg)
GR2A-24D	120	700	5.8	48 lbs. (22 kg)
	208	700	3.4	48 lbs. (22 kg)
	240	700	2.9	48 lbs. (22 kg)
GR2A-30D	120	900	7.5	52 lbs. (24 kg)
	208	900	4.3	52 lbs. (24 kg)
	240	900	3.8	52 lbs. (24 kg)
GR2A-36D	120	1150	9.6	57 lbs. (26 kg)
	208	1150	5.6	57 lbs. (26 kg)
	240	1150	4.8	57 lbs. (26 kg)
GR2A-42D	120	1350	11.3	66 lbs. (30 kg)
	208	1350	6.5	66 lbs. (30 kg)
	240	1350	5.6	66 lbs. (30 kg)
GR2A-48D	120	1600	13.3	77 lbs. (35 kg)
	208	1600	7.7	77 lbs. (35 kg)
	240	1600	6.7	77 lbs. (35 kg)
GR2A-54D	120	1850	15.4	88 lbs. (40 kg)
	208	1850	8.9	88 lbs. (40 kg)
	240	1850	7.7	88 lbs. (40 kg)
GR2A-60D	120	2100	17.5	97 lbs. (44 kg)
	208	2100	10.1	97 lbs. (44 kg)
	240	2100	8.8	97 lbs. (44 kg)
GR2A-66D	120	2320	19.3	107 lbs. (49 kg)
	208	2320	11.2	107 lbs. (49 kg)
	240	2320	9.7	107 lbs. (49 kg)
GR2A-72D	120	2550	21.3	117 lbs. (53 kg)
	208	2550	12.3	117 lbs. (53 kg)
	240	2550	10.6	117 lbs. (53 kg)
GR2A-84D	120	3000	25.0	138 lbs. (63 kg)
	208	3000	14.4	138 lbs. (63 kg)
	240	3000	12.5	138 lbs. (63 kg)

SPECIFICATIONS

ELECTRICAL RATING CHART – GR2AH-XXD MODELS

Model	Voltage	Watts	Amps	Shipping Weight
GR2AH-18D	120	700	5.8	44 lbs. (20 kg)
	208	700	3.4	44 lbs. (20 kg)
	240	700	2.9	44 lbs. (20 kg)
GR2AH-24D	120	1000	8.3	48 lbs. (22 kg)
	208	1000	4.8	48 lbs. (22 kg)
	240	1000	4.2	48 lbs. (22 kg)
GR2AH-30D	120	1320	11.0	52 lbs. (24 kg)
	208	1320	6.4	52 lbs. (24 kg)
	240	1320	5.5	52 lbs. (24 kg)
GR2AH-36D	120	1600	13.3	57 lbs. (26 kg)
	208	1600	7.7	57 lbs. (26 kg)
	240	1600	6.7	57 lbs. (26 kg)
GR2AH-42D	120	1900	15.8	66 lbs. (30 kg)
	208	1900	9.1	66 lbs. (30 kg)
	240	1900	7.9	66 lbs. (30 kg)
GR2AH-48D	120	2200	18.3	77 lbs. (35 kg)
	208	2200	10.6	77 lbs. (35 kg)
	240	2200	9.2	77 lbs. (35 kg)
GR2AH-54D	120	2500	20.1	88 lbs. (40 kg)
	208	2500	12.0	88 lbs. (40 kg)
	240	2500	10.4	88 lbs. (40 kg)
GR2AH-60D	120	2800	23.3	97 lbs. (44 kg)
	208	2800	13.5	97 lbs. (44 kg)
	240	2800	11.7	97 lbs. (44 kg)
GR2AH-66D	120	3120	26.0	107 lbs. (49 kg)
	208	3120	15.0	107 lbs. (49 kg)
	240	3120	13.0	107 lbs. (49 kg)
GR2AH-72D	120	3450	28.8	117 lbs. (53 kg)
	208	3450	16.6	117 lbs. (53 kg)
	240	3450	14.4	117 lbs. (53 kg)
GR2AH-84D	120†	3800	31.7	138 lbs. (63 kg)
	208	4100	19.7	138 lbs. (63 kg)
	240	4100	17.1	138 lbs. (63 kg)

† GR2AH-84 series units, 120 volt, contain tandem heating elements individually controlled.

SPECIFICATIONS

ELECTRICAL RATING CHART – GR2AL-XXD MODELS

Model	Voltage	Watts	Amps		Shipping Weight
			Heating Circuit	Light Circuit	
GR2AL-18D	120	620	4.2	1.0	47 lbs. (21 kg)
	120/208*	620	2.4	1.0	47 lbs. (21 kg)
	120/240*	620	2.1	1.0	47 lbs. (21 kg)
GR2AL-24D	120	820	5.8	1.0	51 lbs. (23 kg)
	120/208*	820	3.4	1.0	51 lbs. (23 kg)
	120/240*	820	2.9	1.0	51 lbs. (23 kg)
GR2AL-30D	120	1020	7.5	1.0	55 lbs. (25 kg)
	120/208*	1020	4.3	1.0	55 lbs. (25 kg)
	120/240*	1020	3.8	1.0	55 lbs. (25 kg)
GR2AL-36D	120	1330	9.6	1.5	61 lbs. (28 kg)
	120/208*	1330	5.6	1.5	61 lbs. (28 kg)
	120/240*	1330	4.8	1.5	61 lbs. (28 kg)
GR2AL-42D	120	1530	11.3	1.5	71 lbs. (32 kg)
	120/208*	1530	6.5	1.5	71 lbs. (32 kg)
	120/240*	1530	5.6	1.5	71 lbs. (32 kg)
GR2AL-48D	120	1840	13.3	2.0	83 lbs. (38 kg)
	120/208*	1840	7.7	2.0	83 lbs. (38 kg)
	120/240*	1840	6.7	2.0	83 lbs. (38 kg)
GR2AL-54D	120•	2090	15.4	2.0	94 lbs. (43 kg)
	120/208*	2090	8.9	2.0	94 lbs. (43 kg)
	120/240*	2090	7.7	2.0	94 lbs. (43 kg)
GR2AL-60D	120•	2400	17.5	2.5	104 lbs. (48 kg)
	120/208*	2400	10.1	2.5	104 lbs. (48 kg)
	120/240*	2400	8.8	2.5	104 lbs. (48 kg)
GR2AL-66D	120•	2620	19.3	2.5	115 lbs. (52 kg)
	120/208*	2620	11.2	2.5	115 lbs. (52 kg)
	120/240*	2620	9.7	2.5	115 lbs. (52 kg)
GR2AL-72D	120•	2910	21.3	3.0	125 lbs. (57 kg)
	120/208*	2910	12.3	3.0	125 lbs. (57 kg)
	120/240*	2910	10.6	3.0	125 lbs. (57 kg)
GR2AL-84D	120•	3420	25.0	3.5	147 lbs. (67 kg)
	120/208*	3420	14.4	3.5	147 lbs. (67 kg)
	120/240*	3420	12.5	3.5	147 lbs. (67 kg)

* Units rated for 120/208 or 120/240 volt are manufactured with a 120 volt circuit for the incandescent lights and a 208 or 240 volt circuit for the heating element(s).

• Not available in Canada.

⚠ CAUTION

Foodwarmers with incandescent lights that require a circuit breaker larger than 20 amps must have a separate circuit breaker for the incandescent lights that is 20 amps or less.

SPECIFICATIONS

ELECTRICAL RATING CHART – GR2AHL-XXD MODELS

Model	Voltage	Watts	Amps		Shipping Weight
			Heating Circuit	Light Circuit	
GR2AHL-18D	120	820	5.8	1.0	47 lbs. (21 kg)
	120/208*	820	3.4	1.0	47 lbs. (21 kg)
	120/240*	820	2.9	1.0	47 lbs. (21 kg)
GR2AHL-24D	120	1120	8.3	1.0	51 lbs. (23 kg)
	120/208*	1120	4.8	1.0	51 lbs. (23 kg)
	120/240*	1120	4.2	1.0	51 lbs. (23 kg)
GR2AHL-30D	120	1440	11.0	1.0	55 lbs. (25 kg)
	120/208*	1440	6.4	1.0	55 lbs. (25 kg)
	120/240*	1440	5.5	1.0	55 lbs. (25 kg)
GR2AHL-36D	120	1780	13.3	1.5	61 lbs. (28 kg)
	120/208*	1780	7.7	1.5	61 lbs. (28 kg)
	120/240*	1780	6.7	1.5	61 lbs. (28 kg)
GR2AHL-42D	120•	2080	15.8	1.5	71 lbs. (32 kg)
	120/208*	2080	9.1	1.5	71 lbs. (32 kg)
	120/240*	2080	7.9	1.5	71 lbs. (32 kg)
GR2AHL-48D	120•	2440	18.3	2.0	83 lbs. (38 kg)
	120/208*	2440	10.6	2.0	83 lbs. (38 kg)
	120/240*	2440	9.2	2.0	83 lbs. (38 kg)
GR2AHL-54D	120•	2740	20.1	2.0	94 lbs. (43 kg)
	120/208*	2740	12.0	2.0	94 lbs. (43 kg)
	120/240*	2740	10.4	2.0	94 lbs. (43 kg)
GR2AHL-60D	120•	3100	23.3	2.5	104 lbs. (48 kg)
	120/208*	3100	13.5	2.5	104 lbs. (48 kg)
	120/240*	3100	11.7	2.5	104 lbs. (48 kg)
GR2AHL-66D	120•	3420	26.0	2.5	115 lbs. (52 kg)
	120/208*	3420	15.0	2.5	115 lbs. (52 kg)
	120/240*	3420	13.0	2.5	115 lbs. (52 kg)
GR2AHL-72D	120•	3810	28.8	3.0	125 lbs. (57 kg)
	120/208*	3810	16.6	3.0	125 lbs. (57 kg)
	120/240*	3810	14.4	3.0	125 lbs. (57 kg)
GR2AHL-84D	120†•	4220	31.7	3.5	147 lbs. (67 kg)
	120/208*	4460	19.7	3.5	147 lbs. (67 kg)
	120/240*	4460	17.1	3.5	147 lbs. (67 kg)

† GR2AHL-84 series units, 120 volt, contain tandem heating elements individually controlled.

* Units rated for 120/208 or 120/240 volt are manufactured with a 120 volt circuit for the incandescent lights and a 208 or 240 volt circuit for the heating element(s).

• Not available in Canada.

⚠ CAUTION

Foodwarmers with incandescent lights that require a circuit breaker larger than 20 amps must have a separate circuit breaker for the incandescent lights that is 20 amps or less.

SPECIFICATIONS

DIMENSIONS-GR2A & GR2AH MODELS

Width (A)	Depth (B)	Height (C)*	Height (D)	Depth (E)†
22"-88" (56-224 cm)	9" (23 cm)	17-1/2" (45 cm)	3-1/2" (9 cm)	5-5/8" (14 cm)

DIMENSIONS-GR2AL & GR2AHL MODELS

Width (A)	Depth (B)	Height (C)*	Height (D)	Depth (E)†
22"-88" (56-224 cm)	12" (30 cm)	17-1/2" (45 cm)	3-1/2" (9 cm)	5-5/8" (14 cm)

DIMENSIONS-GR2A-XXD & GR2AH-XXD MODELS

Width (A)	Depth (B)	Height (C)*	Height (D)	Depth (E)†
22"-88" (56-224 cm)	18"-21" (46-53 cm)	17-1/2" (45 cm)	3-1/2" (9 cm)	5-5/8" (14 cm)

DIMENSIONS-GR2AL-XXD & GR2AHL-XXD MODELS

Width (A)	Depth (B)	Height (C)*	Height (D)	Depth (E)†
22"-88" (56-224 cm)	18"-21" (46-53 cm)	17-1/2" (45 cm)	3-1/2" (9 cm)	5-5/8" (14 cm)

* Includes 14" (36 cm) standard *Designer Legs*.

† Unit shown with optional breath protectors.

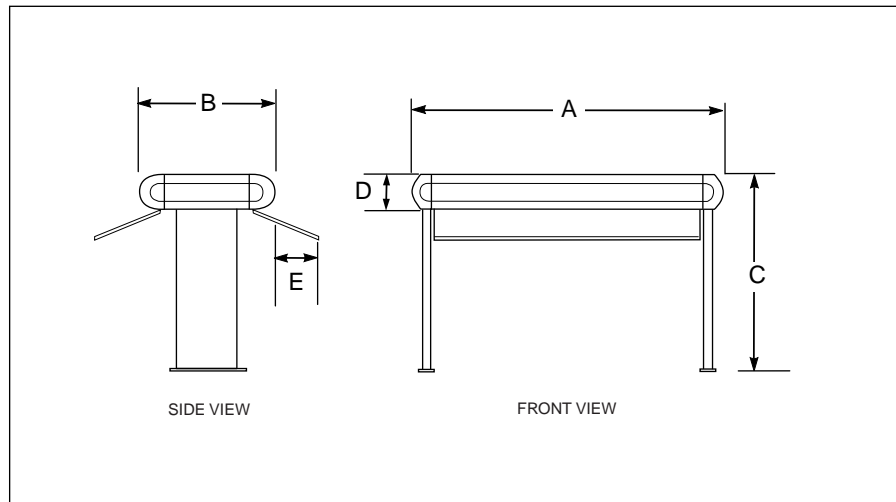

Figure 2. Dimensions

INSTALLATION

LOCATION

⚠ CAUTION

Locate the unit at the proper counter height, in an area that is convenient for use. The location should be level to prevent the unit or its contents from accidentally falling, and strong enough to support the weight of the unit and food displayed.

⚠ WARNING

For safe and proper operation, the unit must be located a reasonable distance from combustible walls and materials. If safe distances are not maintained, discoloration or combustion could occur.

⚠ WARNING

Do not install standard wattage foodwarmer (GR2A & GR2AL Series) less than 17" (43 cm) above nonmetallic surface. Do not install high wattage foodwarmer (GR2AH Series) less than 20" (51 cm) above nonmetallic surface. Do not install high wattage foodwarmer (GR2AHL Series) less than 22" (56 cm) above nonmetallic surface. Do not install standard wattage, dual foodwarmer (GR2A-XXD Series) less than 27" (69 cm) above nonmetallic surface. Do not install high wattage, dual foodwarmer (GR2AH-XXD & GR2AHL-XXD Series) less than 32" (81 cm) above nonmetallic surface. Install all *Designer* foodwarmers so there is a minimum distance of 6" (15 cm) from a nonmetallic wall or adjacent surface.

⚠ CAUTION

Do not add a decorative soffit to hide a pass-through mounted Glo-Ray Foodwarmer.

⚠ CAUTION

All electrical connections must be in accordance with local electrical codes and any other applicable codes. Connections should be made by a qualified, licensed electrician.

PASS THROUGH

If pass-through area is 12" to 16" (31 to 41 cm) wide, the standard wattage or high wattage single unit can be used. For an 18" to 24" (46 to 61 cm) wide pass-through area, a dual unit in either standard or high wattage is recommended. Dual units must always have a minimum spacing of 3" (8 cm) between warmers.

CAUTION

Damage to countertop material such as Corian® and similar products caused by heat generated from Hatco equipment is not covered under the Hatco warranty. Contact the manufacturer of the base material for application information.

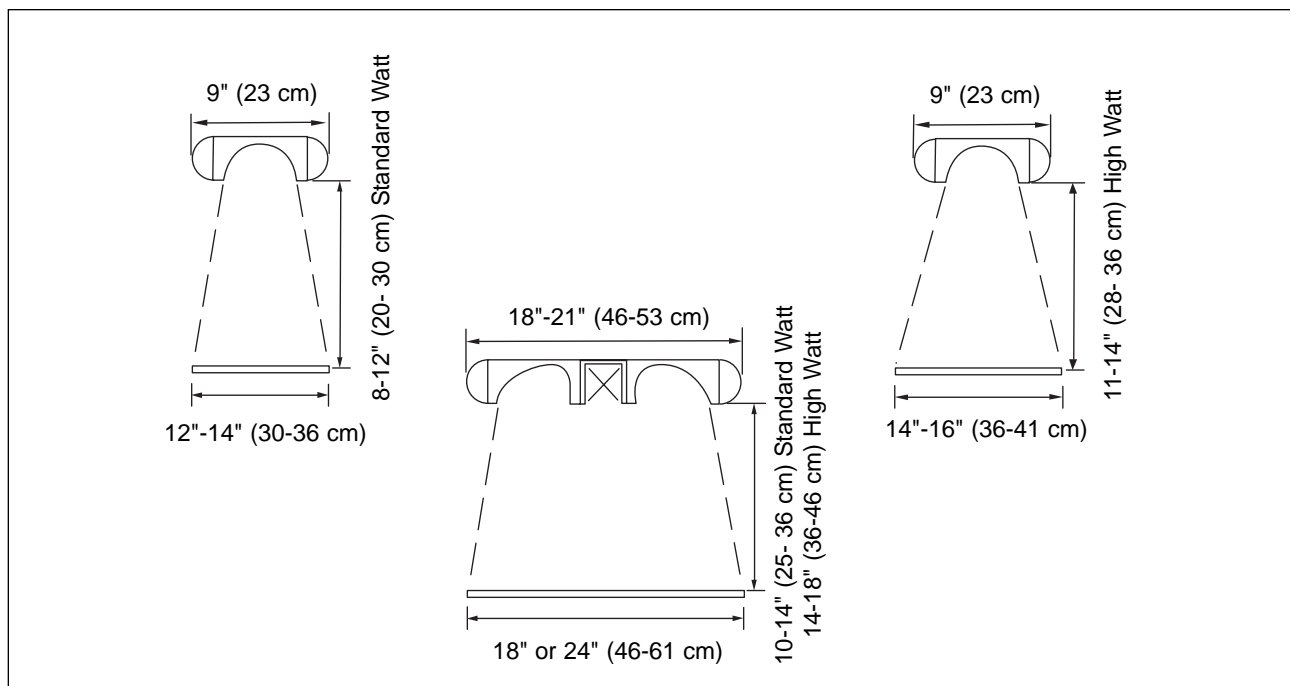

Figure 3. Location Unit

INSTALLATION

ALL MODELS

Glo-Ray *Designer* Infrared Foodwarmers are shipped with most components pre-assembled.

Optional non-adjustable tubular stands (10", 12" and 16") are available from the factory.

Optional breath protectors must be installed on location.

Care should be taken when unpacking shipping carton to avoid damage to unit and components enclosed.

ASSEMBLY

NOTE: *It is recommended that at least two people assist in the assembly/installation of the unit. Longer units may require 3 or more people.*

1. Remove the unit from the carton and lay it upside down on the cardboard.
2. See Figure 4. Remove the extension cover from the tubular stand. It may be necessary to use a rubber mallet.
3. See Figure 4. Place the stand onto the unit with the exposed channel facing outward. Align mounting holes on tubular stand with mounting holes on bracket.
4. Attach angle bracket and stand to mounting bracket with mounting bolts provided. Remove screw from warmer and attach the angle bracket to the warmer using the screw. Tighten all hardware securely.
5. Repeat steps 2 - 4 for other tubular stand.
6. See Figure 5. Position unit onto mounting surface. While holding unit in place, use the flange mounting holes as a template and mark the holes on the mounting surface. Remove the unit and drill the mounting holes.
7. Place the warmer into position over the mounting holes with the electrical conduit positioned through the channel and center mounting hole. Secure the unit to the mounting surface with 1/4 x 1-1/2" hex bolts and nuts provided.

NOTE: *If installing single models side-by-side, a minimum distance of 3" (7.6 cm) must be maintained between warmers.*

8. Reinstall covers to stands by snapping into place.

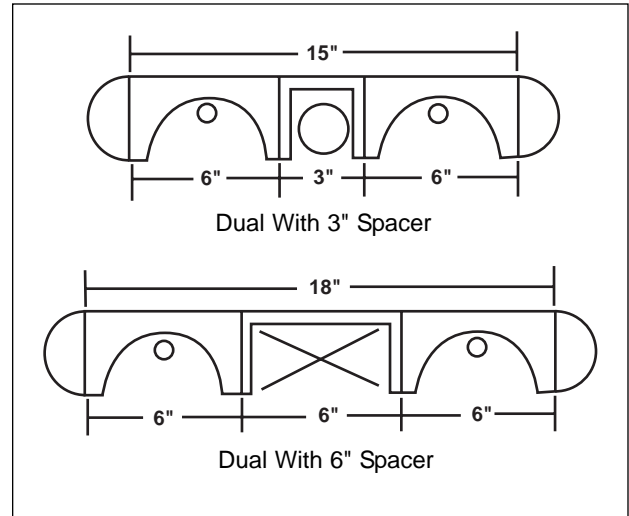

Figure 4. Assembling Dual Units

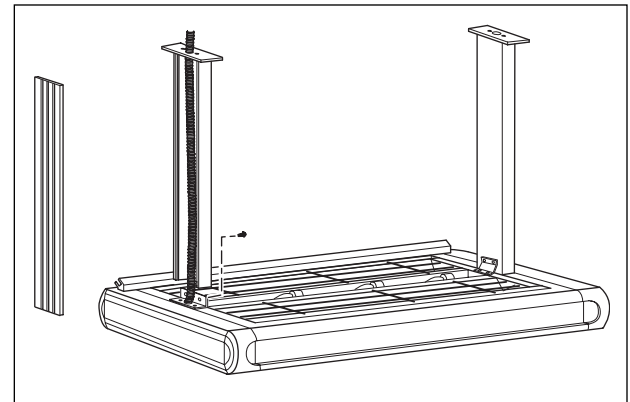

Figure 5. Assembling Tubular Stand To Unit

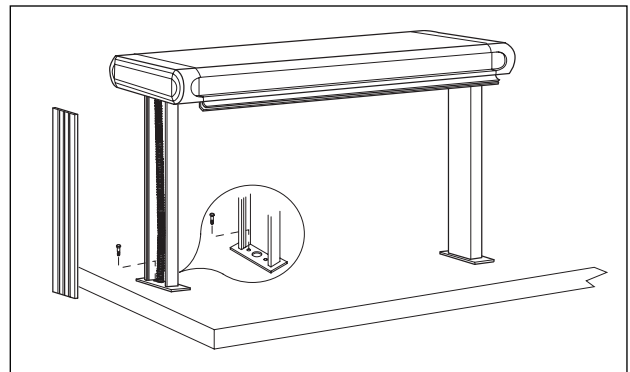

Figure 6. Installing Unit

NOTE: *GR2A series units mounted to a metal surface may require a backing plate installed to the underside of the surface in order to increase unit stability. (Backing plate not supplied by Hatco).*

INSTALLATION

RMB (REMOTE CONTROL BOX)

All models are furnished with a remote control box (RMB). Each RMB comes equipped with the applicable switches for operating the unit. Each heating element is controlled by its own on/off toggle switch or an optional adjustable infinite temperature control. Models equipped with lights have an additional toggle on/off switch for controlling the lights.

Remote control box should be installed by a qualified electrician.

NOTE: If additional RMB's are required, consult the factory for your application.

CAUTION

The remote control box (RMB) must be installed outside of the heat zone.

ELECTRICAL REQUIREMENTS

⚠ CAUTION

All electrical connections must be in accordance with local electrical codes and any other applicable codes. Connections should be made by a qualified, licensed electrician.

⚠ CAUTION

Foodwarmers with incandescent lights that require a circuit breaker larger than 20 amps must have a separate circuit breaker for the incandescent lights that is 20 amps or less.

Refer to *SPECIFICATIONS* for specific model watts and amps ratings.

OPERATION

ALL MODELS

⚠ CAUTION

Some exterior surfaces on the unit will get hot. Use caution when touching these areas to avoid injury.

HEATING ELEMENT(S)

Heating element(s) are controlled by a ON/OFF toggle switch(es) or an optional infinite control(s). To turn each element on, either flip the toggle switch to the ON position or turn the adjustable control to the desired setting.

Allow 15-20 minutes to reach operating temperature.

LIGHTS

On models equipped with lights, flip the toggle switch to the ON position to energize the lights.

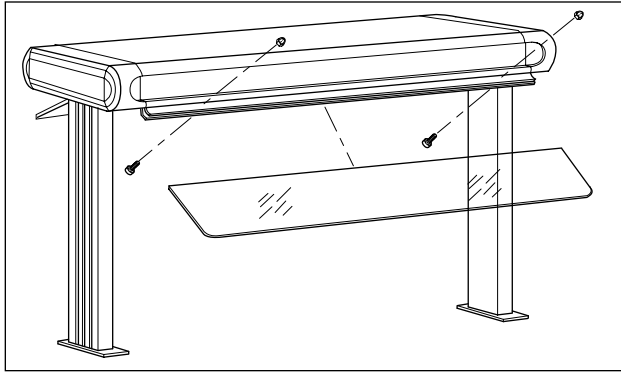

Figure 7. Installing Optional Breath Protectors

Install a supply wire not lighter than 10 gauge copper, rated 90°C (211°F). The remote control box (RMB) provides a 1/2" (1 cm) or 3/4" (2 cm) knockout, 6" (15 cm) long pigtail leads and a separate grounding terminal or screw in the wiring compartment. Use wire nuts (not supplied) for connecting supply wires.

BREATH PROTECTOR (OPTIONAL)

1. Remove protective paper from the acrylic surfaces.
2. See Figure 6. Position the acrylic breath protector into the channel on the warmer with the mounting holes aligned.
3. Secure the breath protector using the thumbscrews and acorn nuts provided. Tighten thumbscrew until snug. Do not overtighten.

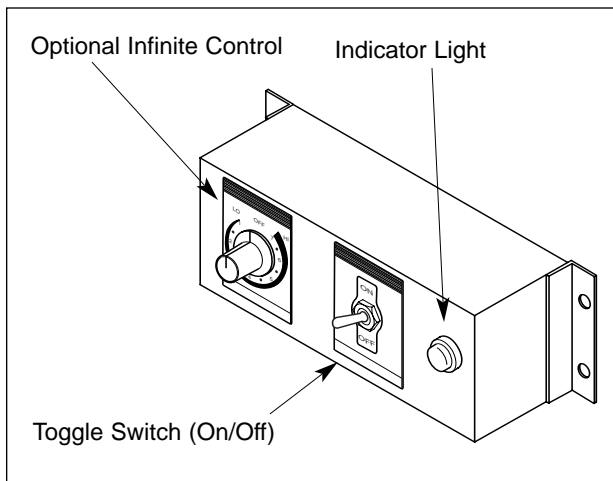

Figure 8. Remote Control Box (RMB)

CLEANING

The Hatco Glo-Ray *Designer* Foodwarmer units are designed for maximum durability and performance, with minimum maintenance.

WARNING

To avoid any injury, turn the power off to the unit and allow to cool before performing any maintenance.

CAUTION

Do not submerge in water.

To preserve the finish of the Glo-Ray *Designer* Foodwarmer, it is recommended that the surfaces be wiped daily with a damp cloth. Stubborn stains may be removed with a good stainless steel cleaner or a non-abrasive cleaner. Hard to reach areas should be cleaned with a small brush and mild soap.

CAUTION

Use only non-abrasive cleaners. Abrasive cleaners could scratch the finish of your unit marring its appearance and making it susceptible to soil accumulation.

DISPLAY LIGHT BULB REPLACEMENT

The display light is an incandescent bulb which illuminates the warming area. This bulb has a special coating to guard against injury and food contamination in the event of breakage.

To replace a bulb, disconnect the power supply and wait until the unit has cooled. Display lamps have a threaded base. Unscrew the bulb from the unit and replace it with a new specially coated incandescent bulb. Hatco shatter-resistant bulbs meet N.S.F. standards for food holding and display areas.

WARNING

Only light bulbs which meet or exceed N.S.F. standards, specifically designed for food holding areas must be used. Breakage of light bulbs not specially coated could result in personal injury and/or food contamination.

WARNING

If service is required on this unit, contact your Authorized Hatco Service Agent, or contact the Hatco Service Department at 800-558-0607 or 414-671-6350; fax 800-690-2966 or International fax 414-671-3976.

WARNING

This product has no “user” serviceable parts. To avoid damage to the unit or injury to personnel, use only Authorized Hatco Service Agents and Genuine Hatco Parts when service is required.

WARNING

Genuine Hatco Replacement Parts are specified to operate safely in the environments in which they are used. Some aftermarket or generic replacement parts do not have the characteristics that will allow them to operate safely in Hatco equipment. It is essential to use Hatco Replacement Parts when repairing Hatco equipment. Failure to use Hatco Replacement Parts may subject operators of the equipment to hazardous electrical voltage, resulting in electrical shock or burn.

HATCO LIMITED WARRANTY

1. PRODUCT WARRANTY

Hatco warrants the products that it manufactures (the "Products") to be free from defects in materials and workmanship, under normal use and service, for a period of one (1) year from the date of purchase when installed and maintained in accordance with Hatco's written instructions. Buyer must establish the product's purchase date by returning Hatco's Warranty Registration Card or by other means satisfactory to Hatco in its sole discretion.

Hatco warrants the following Product components to be free from defects in materials and workmanship from the date of purchase (subject to the foregoing conditions) for the period(s) of time and on the conditions listed below:

- a) **One (1) Year Parts and Labor PLUS One (1) Additional Year Parts-Only Warranty:**
 - Toaster Elements (metal sheathed)
 - Drawer Warmer Elements (metal sheathed)
 - Drawer Warmer Drawer Rollers and Slides
 - Food Warmer Elements (metal sheathed)
 - Infra-Black® Elements (metal sheathed)
 - Display Warmer Elements (metal sheathed air heating)
 - Holding Cabinet Elements (metal sheathed air heating)
 - Cook and Hold Oven Elements (metal sheathed)

- b) **One (1) Year Parts and Labor PLUS Four (4) Additional Years Parts-Only Warranty on pro-rated terms that Hatco will explain at Buyer's Request:**
 - Powermite Gas Booster Heater Tanks
 - Mini Compact Tanks (stainless steel)
 - 3CS and FR Tanks

- c) **One (1) Year Parts and Labor PLUS Four (4) Additional Years Parts-Only Warranty PLUS Five (5) Year Parts-Only Warranty on pro-rated terms that Hatco will explain at Buyer's Request:**
 - Booster Heater Tanks (Castone®)

- d) **One (1) Year Parts-Only Warranty for components not installed by Hatco:**
 - Accessory Components (including but not limited to valves, gauges and remote switches)

THE FOREGOING WARRANTIES ARE EXCLUSIVE AND IN LIEU OF ANY OTHER WARRANTY, EXPRESSED OR IMPLIED, INCLUDING BUT NOT LIMITED TO ANY IMPLIED WARRANTY OF MERCHANTABILITY OR FITNESS FOR A PARTICULAR PURPOSE OR PATENT OR OTHER INTELLECTUAL PROPERTY RIGHT INFRINGEMENT. Without limiting the generality of the foregoing, SUCH WARRANTIES DO NOT COVER: Coated incandescent light bulbs, fluorescent lamps, lamp warmer heat bulbs, glass components or Product failure in booster tank and fin tube heat exchanger caused by liming, sediment buildup, chemical attack or freezing in tanks, Product misuse, tampering or misapplication, improper installation, application of improper voltage, or recalibration of thermostats or high limit switches.

2. LIMITATION OF REMEDIES AND DAMAGES

Hatco's liability and Buyer's exclusive remedy hereunder will be limited solely, at Hatco's option, to repair or replacement by a Hatco-authorized service agency (other than where Buyer is located outside of the United States or Canada, in which case Hatco's liability and Buyer's exclusive remedy hereunder will be limited solely to replacement of part under warranty) with respect to any claim made within the applicable warranty period referred to above. Without limiting the generality of the foregoing, all portable Products (as defined in N.S.F. 4-4.28.4) shall be delivered by Buyer, at its sole expense, to the nearest Hatco-authorized service agency for replacement or repair. Hatco reserves the right to accept or reject any such claim in whole or in part. Hatco will not accept the return of any Product without prior written approval from Hatco, and all such approved returns shall be made at Buyer's sole expense. HATCO WILL NOT BE LIABLE, UNDER ANY CIRCUMSTANCES, FOR CONSEQUENTIAL OR INCIDENTAL DAMAGES, INCLUDING BUT NOT LIMITED TO LABOR COSTS OR LOST PROFITS RESULTING FROM THE USE OF OR INABILITY TO USE THE PRODUCTS OR FROM THE PRODUCTS BEING INCORPORATED IN OR BECOMING A COMPONENT OF ANY OTHER PRODUCT OR GOODS.

HATCO AUTHORIZED PARTS DISTRIBUTORS

ALABAMA

Jones McLeod Appl. Svc.
Birmingham 205-251-0159

ARIZONA

Auth. Comm. Food Equip.
Phoenix 602-234-2443
Byassee Equipment Co.
Phoenix 602-252-0402

CALIFORNIA

Industrial Electric
Huntington Beach 714-379-7100
Chapman Appl. Service
San Diego 619-298-7106
P & D Appliance
S. San Francisco 650-635-1900

COLORADO

All City Service
Denver 303-454-9500
Hawkins Commercial Appliance
Englewood 303-781-5548

DELAWARE

Food Equipment Service
Wilmington 302-996-9363

FLORIDA

Whaley Foodservice Repair
Jacksonville 904-725-7800
Nass Service Co., Inc.
Orlando 407-425-2681
B.G.S.I.
Pompano Beach 954-971-0456
Comm. Appliance Service
Tampa 813-663-0313

GEORGIA

Southeastern Rest. Svc.
Norcross 770-446-6177

HAWAII

Burney's Comm. Service, Inc.
Honolulu 808-848-1466
Food Equip Parts & Service
Honolulu 808-847-4871

ILLINOIS

Parts Town
Broadview 708-865-7278
Eichenauer Elec. Service
Decatur 217-429-4229
Midwest Elec. Appl. Service
Elmhurst 630-279-8000
Cone's Repair Service
Moline 309-797-5323

INDIANA

Comm. Parts & Service, Inc.
Indianapolis 317-545-9655

IOWA

Electric Motor Service Co.
Davenport 319-323-1823

KENTUCKY

Comm. Parts & Service, Inc.
Louisville 502-367-1788

LOUISIANA

Chandlers Parts & Service
Baton Rouge 225-272-6620

LOUISIANA (Continued)

Bana Comm. Parts, Inc.
Shreveport 318-631-6550

MARYLAND

Electric Motor Service
Baltimore 410-467-8080
GCS Service, Inc.
Silver Spring 301-585-7550

MASSACHUSETTS

Ace Service Co., Inc.
Needham 781-449-4220

MICHIGAN

Commercial Kitchen Service
Bay City 517-893-4561
Bildons Appliance Service
Detroit 248-478-3320
Midwest Food Equip. Service
Grandville 616-261-2000

MINNESOTA

GCS Service
Minneapolis 612-546-4221

MISSOURI

GCS Service, Inc.
Kansas City 816-920-5999
Commercial Kitchen Services
St. Louis 314-890-0700
Kaemmerlen Parts & Service
St. Louis 314-535-2222

NEBRASKA

Anderson Electric
Omaha 402-341-1414

NEVADA

Burney's Commercial
Las Vegas 702-736-0006
Hi. Tech Commercial Service
N. Las Vegas 702-649-4616

NEW JERSEY

Jay Hill Repair
Fairfield 973-575-9145
Service Plus
Flanders 973-691-6300

NEW YORK

Acme American Repairs, Inc.
Brooklyn 718-456-6544
Alpro Service Co.
Brooklyn 718-386-2515
Appliance Installation
Buffalo 716-884-7425
Northern Parts Dist.
Plattsburgh 518-563-3200
J. B. Brady, Inc.
Syracuse 315-422-9271

NORTH CAROLINA

Authorized Appliance
Charlotte 704-377-4501

OHIO

Akron/Canton Comm. Svc. Inc.
Akron 330-753-6635
Certified Service Center
Cincinnati 513-772-6600
GCS Service
Columbus 614-476-3225

OHIO (Continued)

Electrical Appl. Repair Service
Independence 216-459-8700
E. A. Wichman Co.
Toledo 419-385-9121

OKLAHOMA

Hagar Rest. Service, Inc.
Oklahoma City 405-235-2184
Krueger, Inc.
Oklahoma City 405-528-8883

OREGON

Bressie Electric Co.
Portland 503-231-7171
Ron's Service, Inc.
Portland 503-624-0890

PENNSYLVANIA

Authorized Factory Service
Coraopolis 412-262-2330
FAST Comm. Appl. Service
Philadelphia 215-288-4800
GCS Service, Inc.
Pittsburgh 412-787-1970
K & D Service Co.
Harrisburg 717-236-9039
Elmer Schultz Services
Philadelphia 215-627-5401
Electric Repair Co.
Reading 610-376-5444

RHODE ISLAND

Marshall Electric Co.
Providence 401-331-1163

SOUTH CAROLINA

Whaley Foodservice Repair
W. Columbia 803-791-4420

TENNESSEE

Camp Electric
Memphis 901-527-7543

TEXAS

City Kitchen Service Co.
Austin 512-719-4445
Stove Parts Supply
Fort Worth 817-831-0381
Armstrong Repair Service
Houston 713-666-7100
Commercial Kitchen Repair Co.
San Antonio 210-735-2811
San Antonio Rest. Equip.
San Antonio 210-824-3271

UTAH

Peterson's Commercial Parts & Svc.
Salt Lake City 801-487-3653

VIRGINIA

Daubers
Norfolk 757-855-4097
Daubers
Springfield 703-866-3600

WASHINGTON

Restaurant Appl. Service
Seattle 206-524-8200

WISCONSIN

A.S.C., Inc.
Madison 608-246-3160
A.S.C., Inc.
Milwaukee 414-543-6460

HATCO CORPORATION

P.O. Box 340500, Milwaukee, WI 53234-0500 U.S.A.

(800) 558-0607 (414) 671-6350

Parts & Service Fax (800) 690-2966 Int'l. Fax (414) 671-3976

www.hatcocorp.com