

HOLDING & DISPLAY
CABINETS



*Heat up your
impulse-buy sales.*



*Fresh merchandising ideas for
daytime, nighttime and all of
the snack times in between.*



FSD

FLAV-R-SAVOR® HUMIDIFIED DISPLAY CABINETS

Choose display cabinets that will work harder for you around the clock. Choose Flav-R-Savor from Hatco.

Balancing the right combination of heat and humidity, the rugged Flav-R-Savor humidified cabinet keeps food fresh and safe for up to four hours, reducing waste and maintaining the high quality you need to satisfy your customers.

Plus, with a complete range of sizes, door options and rack types, you can select the cabinet that will let you sell more whether it's breakfast, lunch or dinner.

- Keep food hot and fresh at safe temperatures
- Internal fluorescent lighting helps showcase product
- Full cabinet display with tempered glass doors and side panels retains maximum heat
- Heat is diffused throughout cabinet providing gentle, even heat
- Continuous humidity keeps food fresher
- Two-door models offer pass-through convenience

FSDT

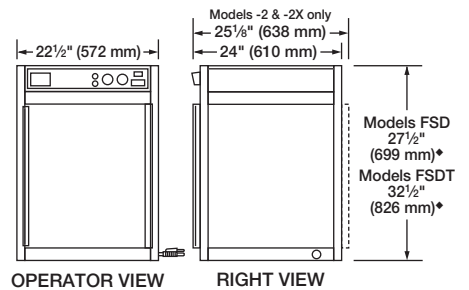

DIMENSIONS

Cabinet Openings: FSD – 19"W x 18 5/8"H (483 x 473 mm).
 FSDT – 19"W x 23 3/4"H (483 x 603 mm).

♦ Add 1" (25 mm) to height for display sign.

Choose a *Designer Color* to match any décor.



Printed colors are a representation and may not exactly match our *Designer colors*.

CUSTOM FOOD DECALS:

Pizza, Chicken, Pretzel, Croissant/Biscuit



**HUMIDIFIED
HOLDING & DISPLAY
CABINETS**

CONTROLLED MOISTURIZED HEAT KEEPS HOT FOODS FRESH, LONGER

The Hatco "operator friendly" control panel makes it easy to set the correct heat and humidity levels. Convenient dials regulate temperature and moisture, while a green light indicates the humidity-cycle. A red light signals low-water in the reservoir. The cabinet heat is monitored by a temperature indicator, and a front-fill reservoir cup makes it easy to add water.

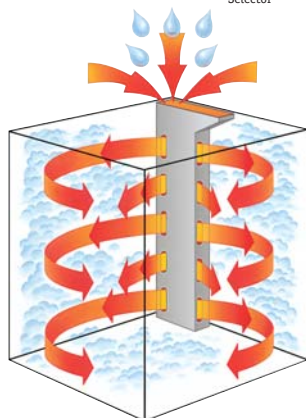
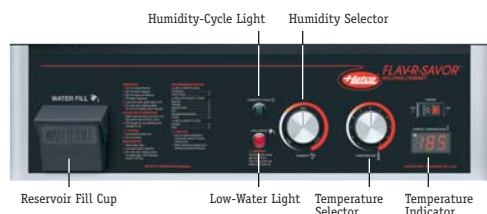

Model FSD-2X with 3-tier pan rack, accessory decals, and pans



Model FSDT-1 with rotating rack motor, 4-tier circle rack, optional *Designer* color, accessory decals, and pans

SPECIFICATIONS

Standard Models

Model*	Type	Rack Style†	Shipping Weight
FSD-1	1 Door	3-Tier Circle Rack w/Motor	113 lbs. (51 kg)
FSD-1X	1 Door	3-Tier Pan Rack w/o Motor	111 lbs. (50 kg)
FSD-2	2 Doors	3-Tier Circle Rack w/Motor	114 lbs. (52 kg)
FSD-2X	2 Doors	3-Tier Pan Rack w/o Motor	112 lbs. (51 kg)

Tall Models

Model*	Type	Rack Style†	Shipping Weight
FSDT-1	1 Door	4-Tier Circle Rack w/Motor	120 lbs. (54 kg)
FSDT-1X	1 Door	4-Tier Pan Rack w/o Motor	118 lbs. (54 kg)
FSDT-2	2 Doors	4-Tier Circle Rack w/Motor	122 lbs. (55 kg)
FSDT-2X	2 Doors	4-Tier Pan Rack w/o Motor	120 lbs. (54 kg)

* Models FSD-1, FSD-2, FSDT-1, and FSDT-2 include display motor. Models with "X" designator do not have revolving display and are NOT available for retrofit.

† Rack listed is included with unit. Optional racks available, see Display Rack Selection.

VOLTAGE

120 volts, 60 Hz, 1440 watts, 12 amps (NEMA 5-15P). Export voltages available, see specification sheet.

CORD LOCATION

Facing controls, right-hand side panel, lower right corner.

WATER TANK CAPACITY

¾ gallon (3 liters).

WATER QUALITY REQUIREMENTS

Water supply in excess of 3.0 grains of hardness per gallon (GPG) (.75 grains of hardness per liter) must be treated and softened before being used. Water containing over 3.0 GPG (.75 GPL) will decrease the efficiency and reduce the operating life of the unit. *Note: Product failure caused by liming or sediment buildup is not covered under warranty.*

DISPLAY RACK SELECTIONS

(Racks shown are for FSD models only)

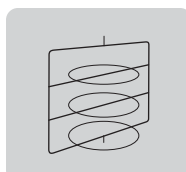

3-Tier Circle Rack ▲
(Max. 19" Dia. (483 mm) Pans)
(Rack Opening 4⁵/₈" (117 mm))

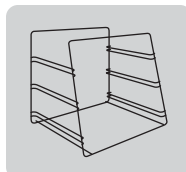

3-Tier Pan Rack
(Max. 18" x 13" (457 x 330 mm)
Half-Size Sheet Pans)
(Rack Opening 3¹/₂" (89 mm))

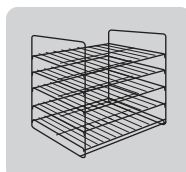

5-Shelf Multi-Purpose Rack
(Max. 18" x 13" (457 x 330 mm)
Half-Size Sheet Pans)
(Rack Opening 2¹/₂" (64 mm))

DISPLAY RACK SELECTIONS

(Racks shown are for FSDT models only)

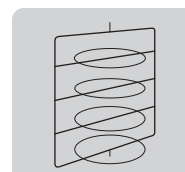

4-Tier Circle Rack ▲
(Max. 19" Dia. (483 mm) Pans)
(Rack Opening 4⁵/₈" (117 mm))

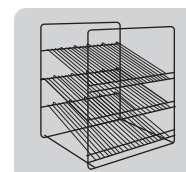

3-Shelf Angle Rack
(Rack Opening 3¹/₂" (89 mm))



4-Tier Pan Rack
(Max. 18" x 13" (457 x 330 mm)
Half-Size Sheet Pans)
(Rack Opening 3¹/₂" (89 mm))

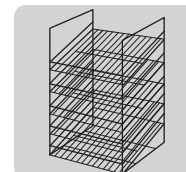

5-Shelf Angle Rack
(Rack Opening 2¹/₂" (64 mm))

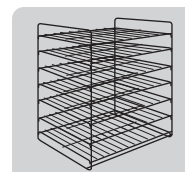

7-Shelf Multi-Purpose Rack
(Max. 18" x 13" (457 x 330 mm)
Half-Size Sheet Pans)
(Rack Opening 2¹/₂" (64 mm))

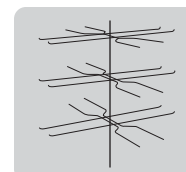

3-Tier Pretzel Tree ▲
(Rack Opening 5¹/₈" (149 mm))

▲ Requires motorless rack coupling on -X Models

COUNTERTOP

HUMIDIFIED HOLDING & DISPLAY CABINETS



Model FDWD-1 with rotating rack motor, 4-tier circle rack, optional three-sided sign holder (signs not included), and accessory pans

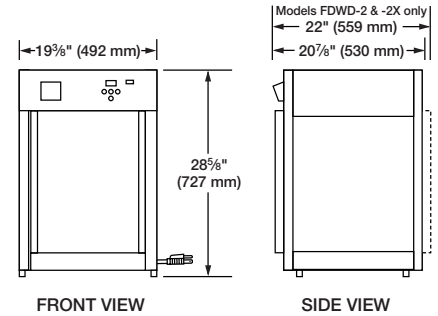

DIMENSIONS

Cabinet Opening: 15 3/4" W x 19 3/4" H (400 x 502 mm).

FDWD

FLAV-R-FRESH® HUMIDIFIED DISPLAY CABINETS

It's time to make a maximum impact on your bottom line using a minimum of counterspace. The compact Flav-R-Fresh line gives you a profitable way to increase your impulse-buy sales.

- Separate humidity and heat controls keep crisp foods crisp and moist foods moist for hours
- Large single door models provide fast access to food racks
- Reversible two door models offer pass-through convenience
- A variety of racks add flexibility and merchandising appeal
- Ideal for restaurants, pizzarias, convenience stores, concession stands, snack bars, and kiosks



Model FDWD-2X with accessory 4-shelf angle rack

CUSTOM FOOD DECALS:

Pizza, Hot Pizza, Hot Pretzels



DISPLAY RACK SELECTIONS

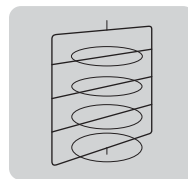

4-Tier Circle Rack ▲
(Max. 15" Dia.
(381 mm) Pans)
(Rack Opening
3 1/4" (83 mm))

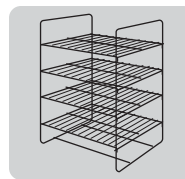

4-Shelf Multi-Purpose Rack
(Max. 18" x 13"
(457 x 330 mm)
Half-Size Sheet Pans)
(Rack Opening
3 1/2" (89 mm))

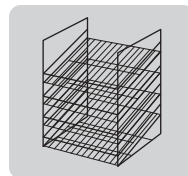

4-Shelf Angle Rack
(Rack Opening
3 3/4" (95 mm))

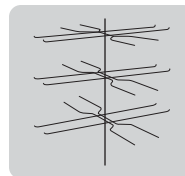

3-Tier Pretzel Tree ▲
(Rack Opening
5 7/8" (149 mm))

▲ Requires motorless rack coupling on -X Models

Choose a Designer Color to match any décor.



Warm Red



Black



Gray Granite



White Granite



Navy Blue



Hunter Green



Antique Copper

Printed colors are a representation and may not exactly match our Designer colors.

SPECIFICATIONS

Model*	Type	Rack Style	Shipping Weight
FDWD-1	1 Door	Circle Rack† with Rack Motor	80 lbs. (36 kg)
FDWD-1X	1 Door	Multi-Purpose Rack without Rack Motor	82 lbs. (37 kg)
FDWD-2	2 Doors	Circle Rack† with Rack Motor	86 lbs. (39 kg)
FDWD-2X*2	2 Doors	Multi-Purpose Rack without Rack Motor	88 lbs. (40 kg)

* Models FDWD-1 and FDWD-2 include rack motor. Models with "X" designator do not have revolving display and are NOT available for retrofit.

† Pretzel Rack available as substitute for Circle Rack.

* Accommodates half-size sheet pans.

VOLTAGE

120 volts, 60 Hz, 1420 watts, 11.8 amps (NEMA 5-15P).

Export voltages available, see specification sheet.

CORD LOCATION

Facing controls, right-hand side panel, lower right corner.

WATER TANK CAPACITY

1/2 gallon (2 liters).

WATER QUALITY REQUIREMENTS

Water supply in excess of 3.0 grains of hardness per gallon (GPG) (.75 grains of hardness per liter) must be treated and softened before being used. Water containing over 3.0 GPG (.75 GPL) will decrease the efficiency and reduce the operating life of the unit.

Note: Product failure caused by liming or sediment buildup is not covered under warranty.

COUNTERTOP

NON-HUMIDIFIED HOLDING & DISPLAY CABINETS

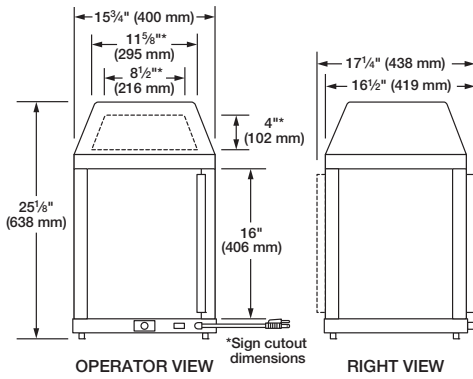

DIMENSIONS

Cabinet Opening: 12½"W x 16"H (318 x 406 mm).
Trapezoid Shape Sign Holder: 8½"W at top x 4"H x 11⅝"W at bottom (216 x 102 x 295 mm).

SPECIFICATIONS

Model	Type	Rack Style	Shipping Weight
MDW-1X	1 Doors	3-Shelf Adjustable	46 lbs. (21 kg)
MDW-2X	2 Doors	3-Shelf Adjustable	48 lbs. (22 kg)

VOLTAGE

120 volts, 470 watts, 3.9 amps (NEMA 5-15P).

CORD LOCATION

Facing controls, lower right corner.

Choose a *Designer Color* to match any décor.



Warm Red Black Gray Granite White Granite Navy Blue



Hunter Green Antique Copper

Printed colors are a representation and may not exactly match our *Designer* colors.



Model MDW-1X
In *Designer* black with optional hood with backlit sign cutout on one side (graphic included)

MINI DISPLAY WARMER NON-HUMIDIFIED DISPLAY CABINETS

Warm cookies. Hot sandwiches. Soft pretzels. Make anytime the right time for these types of items. This non-humidified, compact model keeps them hot and ready for your customers to grab-and-go.

- Merchandising flexibility thanks to magnetically adjustable slant or horizontal shelves for maximum visibility
- Single-door or pass-through models available for server and self-serve operations
- Perfect for locations with limited counterspace

MDW



SPECIALTY COUNTERTOP

HUMIDIFIED Holding & Display Cabinets

Model WFST-2X with 4-shelf multi-purpose rack, optional *Designer* color and sliding doors, and accessory pans



Choose a *Designer* Color to match any décor.



Printed colors are a representation and may not exactly match our *Designer* colors.

WFST

FLAV-R-SAVOR® HUMIDIFIED LARGE CAPACITY DISPLAY CABINETS

Expecting peak crowds at meal time? Turn to the larger capacity Flav-R-Savor Wide Display Cabinet. Place hot product straight from the oven directly into the full-view cabinets and increase your impulse sales.

- Holds standard 18" x 26" (457 x 660 mm) sheet pans for efficient kitchen operation
- Multipurpose display rack included
- Optional self-closing sliding doors for self-serve applications
- Stacking kit available to maximize floor space and double display capacity



CUSTOM FOOD DECALS:

Chicken, Ribs, Today's Hot Specials



Today's Hot Specials

DIMENSIONS

Cabinet Opening: 28"W x 21 $\frac{7}{8}$ "H (711 x 556 mm).

SPECIFICATIONS

Model	Type	Rack Style	Shipping Weight
WFST-1X	2 Doors	4-Shelf Stationary	163 lbs. (74 kg)
WFST-2X	4 Doors	4-Shelf Stationary	188 lbs. (85 kg)

VOLTAGE

120 volts, 60 Hz, 1790 watts, 14.9 amps (NEMA 5-15P, NEMA 5-20P – Canada).

Export voltages available, see specification sheet.

CORD LOCATION

Facing controls, left-hand side panel, lower right corner.

WATER TANK CAPACITY

$\frac{3}{4}$ gallon (3 liters).

WATER QUALITY REQUIREMENTS

Water supply in excess of 3.0 grains of hardness per gallon (GPG) (.75 grains of hardness per liter) must be treated and softened before being used. Water containing over 3.0 GPG (.75 GPL) will decrease the efficiency and reduce the operating life of the unit.

Note: Product failure caused by liming or sediment buildup is not covered under warranty.



Model WFST-1X with 4-shelf multi-purpose rack and accessory decals and pans

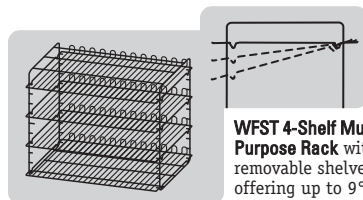
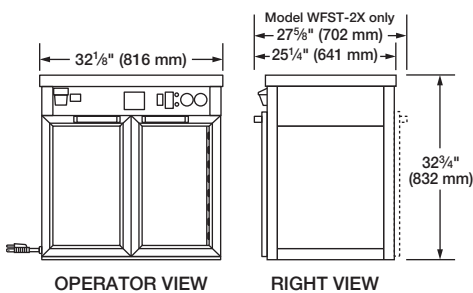

WFST 4-Shelf Multi-Purpose Rack with removable shelves offering up to 9° angle of flexibility (3" (76 mm) difference from front to back)



Model WFST-1X operator side

NON-HUMIDIFIED
Holding & Display
Cabinets



Model LFST-48 with 3-shelf multi-purpose rack, sign holders (graphic not included), and optional Designer color

DIMENSIONS

Cabinet Opening: 42 $\frac{7}{8}$ "W x 21 $\frac{7}{8}$ "H (1089 x 556 mm).

SPECIFICATIONS

Model	Type	Rack Style	Shipping Weight
LFST-48	4 Doors	3-Shelf Stationary	190 lbs. (86 kg)

VOLTAGE

120/208-240 volts, 2150 watts, 14.6 amps (NEMA L14-20P).

Export voltages available, see specification sheet.

CORD LOCATION

Facing controls, left-hand side panel, lower right corner.

Choose a *Designer Color* to match any décor.



Printed colors are a representation and may not exactly match our *Designer* colors.

FLAV-R-SAVOR®
NON-HUMIDIFIED LARGE CAPACITY
DISPLAY CABINETS

When capacity is an issue and humidified heat is not needed, choose the Hatco Large Capacity Display Cabinet. Items such as wraps and sandwiches can be prepared in advance and still stay hot, safe and tasty with this large model. And you will always be ready for your daily rush – whatever time it occurs.

- Perfect for large quantities of wrapped or boxed food
- Sign holders on all four sides for easy personalization (signs not included)
- Holds two standard sheet pans side-by-side on three shelves for increased product visibility and easy accessibility

LFST

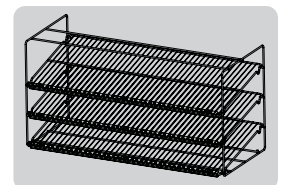
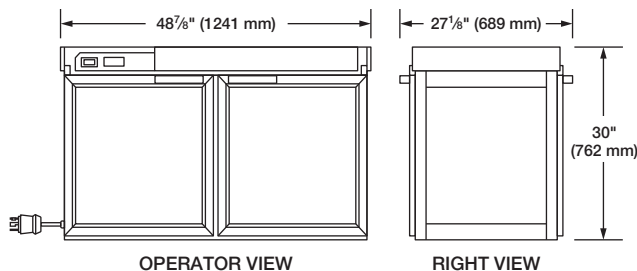

LFST 3-Shelf Multi-Purpose Rack with Non-Adjustable Shelves

SPECIALTY COUNTERTOP

NON-HUMIDIFIED Holding & Display Cabinets

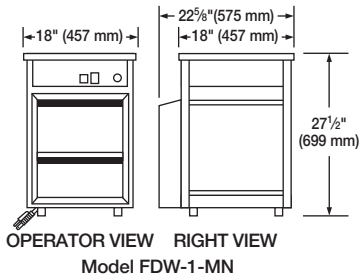

Model FDW-1-MN



MACHO NACHO® CHIP WARMERS

MN

When it's time for a snack, Macho Nacho is always ready. Keep your chips hot, crisp and tasty with this specialty warmer and display unit. The unique two-door design allows for first-in, first-out chip delivery. And since Macho Nacho circulates air to prevent the loss of natural oils, you will not need to replace stale chips.

- Hold 25 or 40 pounds (11 or 18 kg) of chips in a very small footprint, reducing refill time
- Two-door access permits easy loading and serving
- Special ductwork forces heat through chips from the bottom up, providing efficient heating

DIMENSIONS

FDW-1-MN:

Cabinet Openings: Upper Door 15 1/4"W x 9 1/4"H (387 x 235 mm).
Lower Door 15 1/4"W x 9 1/4"H (387 x 235 mm).

FST-1-MN:

Cabinet Openings: Upper Door 18 1/4"W x 11 1/4"H (464 x 286 mm).
Lower Door 18 1/4"W x 9 1/4"H (464 x 235 mm).

SPECIFICATIONS

Model	Type	Shipping Weight
FDW-1-MN	2 Doors	80 lbs. (36 kg)
FST-1-MN	2 Doors	132 lbs. (60 kg)

VOLTAGE

FDW-1-MN: 120 volts, 1128 watts, 9.4 amps (NEMA 5-15P).

FST-1-MN: 120 volts, 1245 watts, 10.4 amps (NEMA 5-15P).

Export voltages available, see specification sheet.

CORD LOCATION

FDW-1-MN: Facing controls, bottom left corner.

FST-1-MN: Facing controls, left-hand side panel, lower right corner.

PRODUCT CAPACITY

FDW-1-MN: 25 lbs. (11 kg).

FST-1-MN: 40 lbs. (18 kg).

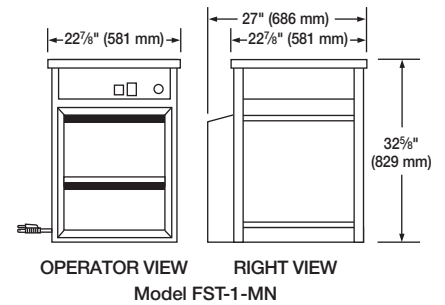

Model FST-1-MN



SPECIALTY COUNTERTOP

HEATED AIR CURTAIN Cabinets

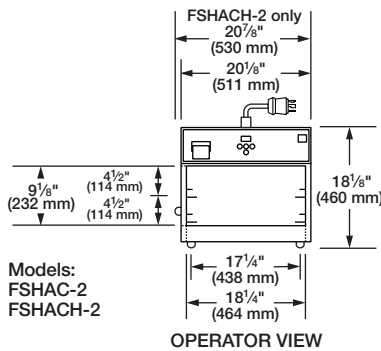

Models:
FSHAC-2
FSHACH-2

OPERATOR VIEW

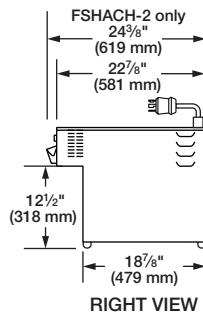

RIGHT VIEW



Model FSHACH-2
with accessory pans

DIMENSIONS

Cabinet Opening

FSHAC-2, FSHACH-2: 18 1/4"W x 9 1/8"H (464 x 232 mm).

FSHAC-3, FSHACH-3: 18 1/4"W x 18 1/8"H (464 x 460 mm).

FSHAC-2PT, FSHACH-2PT: 18 1/4"W x 9 1/4"H (464 x 235 mm).

SPECIFICATIONS

Model	Type	Shipping Weight
FSHAC-2	2-Tier	100 lbs. (45 kg)
FSHACH-2	2-Tier Humidified	100 lbs. (45 kg)
FSHAC-3	3-Tier	115 lbs. (52 kg)
FSHACH-3	3-Tier Humidified	115 lbs. (52 kg)
FSHAC-2PT	2-Tier Pass-Through	150 lbs. (68 kg)
FSHACH-2PT	2-Tier Humidified Pass-Through	150 lbs. (68 kg)

VOLTAGE

FSHAC-2: 120 volts, 60 Hz, 1850 watts, 15.4 amps (NEMA 5-20P).

FSHAC-2, -3: 120/208 volts, 60 Hz, 1877 watts, 9.0 amps (NEMA L14-20P).

FSHAC-2PT: 120/208 volts, 60 Hz, 3152 watts, 15.2 amps (NEMA L14-20P).

FSHAC-2PT: 208 volts, 60 Hz, 3152 watts, 15.2 amps (NEMA L6-20P).

FSHAC-2PT: 240 volts, 60 Hz, 3200 watts, 13.3 amps (NEMA L6-20P).

FSHACH-2, -3: 120/208 volts, 60 Hz, 2950 watts, 14.2 amps (NEMA L14-20P).

FSHACH-2PT: 120/208 volts, 60 Hz, 4952 watts, 23.8 amps (NEMA L14-30P).

FSHACH-2PT: 208 volts, 60 Hz, 4952 watts, 23.8 amps (NEMA L6-30P).

CORD LOCATION

FSHAC-2, -3, FSHACH-2, -3: Top of unit towards the back, middle.

FSHAC-2PT, FSHACH-2PT: Top of unit towards the back, left side.

WATER TANK CAPACITY (Humidified Models)

FSHACH-2, -3: 2 1/4 gallons (9 liters).

FSHACH-2PT: 3 gallons (11 liters).

WATER QUALITY REQUIREMENTS

Water supply in excess of 3.0 grains of hardness per gallon (GPG) (.75 grains of hardness per liter) must be treated and softened before being used. Water containing over 3.0 GPG (.75 GPL) will decrease the efficiency and reduce the operating life of the unit.

Note: Product failure caused by liming or sediment buildup is not covered under warranty.

FLAV-R-SAVOR® HUMIDIFIED & NON-HUMIDIFIED HEATED AIR CURTAIN CABINETS

Deliver exactly what your clientele hungers for anytime of the day. The patented Flav-R-Savor Heated Air Curtain Cabinets give you immediate access to food with no doors to slow you down during your daily rush. Peak rush times can challenge your operation – Hatco helps you meet this demand with ease.

- A "curtain" of heated air is created by warm air being forced downward through ducts above the opening and then drawn towards the back of the unit
- Perfect for wrapped product and product on sheet pans
- Available in sizes to accommodate half-size or full-size sheet pans
- Available in both humidified and non-humidified to match your product offering

FSHAC

FSHACH



Model FSHACH-2PT
Pass-through with
accessory pans



Model FSHACH-3



Removable
Slant Rack

Removable
Rib Rack

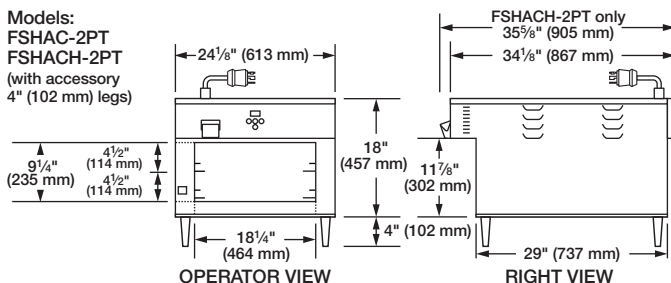

Models:
FSHACH-2PT
FSHACH-2PT
(with accessory
4" (102 mm) legs)

OPERATOR VIEW

RIGHT VIEW

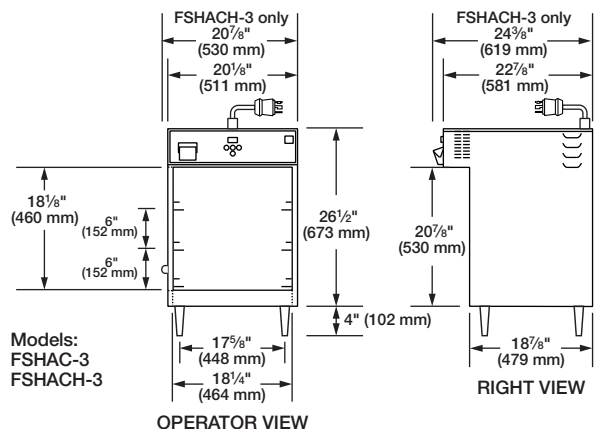

Models:
FSHACH-3
FSHACH-3

OPERATOR VIEW

RIGHT VIEW

PORTABLE

**HUMIDIFIED
HOLDING & DISPLAY
CABINETS**



Model FSHC-7-1 with standard 4" (102 mm) casters, tray slides, and accessory food pans

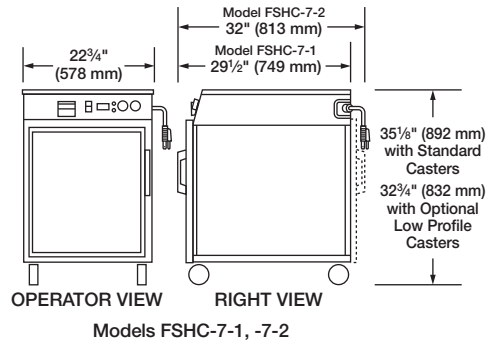

DIMENSIONS

Cabinet Opening: FSHC-7-1, -7-2 – 18 1/2"W x 22"H (470 x 559 mm).
 FSHC-6W1, -6W2 – 21 1/2"W x 19"H (546 x 483 mm).
 Top Surface: FSHC-7-1, -7-2 – 22 5/8"W x 25 7/8"D (575 x 657 mm).
 FSHC-6W1, -6W2 – 25 3/8"W x 25 7/8"D (645 x 657 mm).

SPECIFICATIONS

Model	Type	Rack Style	Shipping Weight
FSHC-7-1	1 Door	Adjustable Angle Slides*	168 lbs. (76 kg)
FSHC-7-2 [▲]	2 Doors	Adjustable Angle Slides*	172 lbs. (78 kg)
FSHC-6W1	1 Door	Adjustable Angle Slides*	175 lbs. (79 kg)
FSHC-6W2 [▲]	2 Doors	Adjustable Angle Slides*	179 lbs. (81 kg)

* 7 slides on each side standard. Additional slides available. Sheet Pans not included.
[▲] FSHC-7-2 and FSHC-6W2 are each a two-door pass-through single cabinet, not two units stacked.
 • 6 slides on each side standard. Additional slides available. Sheet Pans not included.

VOLTAGE

FSHC-6W1, -6W2: 120 volts, 60 Hz, 1697 watts, 14.1 amps (NEMA 5-15P, NEMA 5-20P – Canada).
 FSHC-7-1, -7-2: 120 volts, 60 Hz, 1697 watts, 14.1 amps (NEMA 5-15P, NEMA 5-20P – Canada).
 Export voltages available, see specification sheet.

CORD LOCATION

Back of unit, upper right side.

WATER TANK CAPACITY

FSHC-6W1, -6W2: 1 1/4 gallons (5 liters).
 FSHC-7-1, -7-2: 3/4 gallon (3 liters).

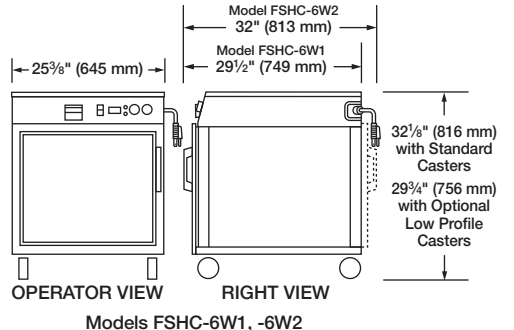

FSHC-7

**FLAV-R-SAVOR®
LOW PROFILE & PORTABLE
HUMIDIFIED HOLDING CABINETS**

When it's time for flexibility, turn to Hatco portable cabinets. You'll find the fit that's right for you with the Flav-R-Savor Low Profile or standard Portable Holding Cabinets. The low profile model is perfect for under work counters, and they are all easy to move and maneuver when necessary.

FSHC-6

- Accommodates full sheet pans or Gastronorm pans
- Insulated side walls, field reversible glass doors, large swivel casters with wheel locks, and 6' (1829 mm) cord and plug are standard
- Perfect for serving counters, buffet lines, drive-up windows, point-of-service or preparation areas



Model FSHC-6W1 with accessory pans



Models FSHC-7-1/FSHC-7-1 with accessory stacking hardware and pans

Choose a Designer Color to match any décor.

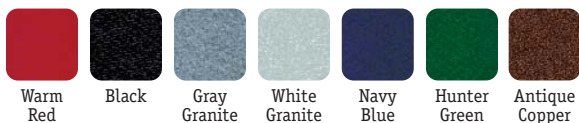

Printed colors are a representation and may not exactly match our Designer colors.

PORTABLE

**HUMIDIFIED
HOLDING & DISPLAY
CABINETS**

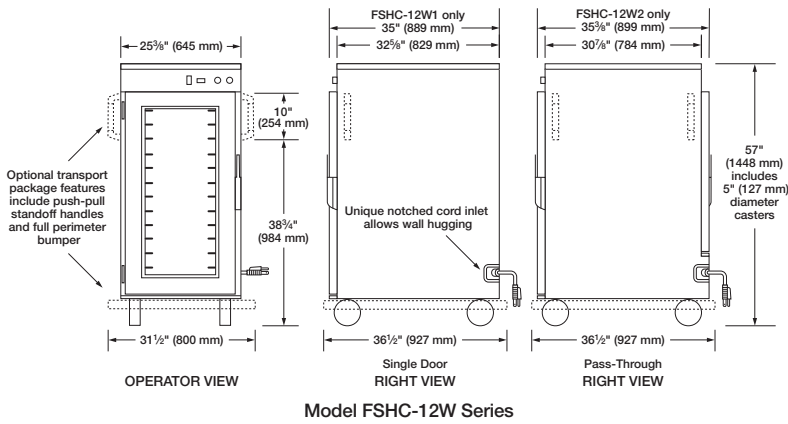

Model FSHC-12W1
with accessory food pans

**FLAV-R-SAVOR®
TALL HUMIDIFIED
HOLDING CABINETS**

People want lots of menu choices – yet often don't have time to wait for food to be prepared from start to finish at the time of order. Give your customers more menu choices and hold larger quantities of proven favorites ahead of peak serving periods with these Flav-R-Savor Tall Humidified Holding Cabinets.

- Hold full sheet, Gastronorm, or steam table pans
- Two sizes to fit your kitchen's needs
- Models are available with pass-through design
- Dutch doors available on FSHC-17W models
- Temperatures from 90° – 200°F (32° – 82°C) will accommodate proofing



FSHC-12

FSHC-17



Model FSHC-17W1
with accessory food pans

DIMENSIONS

Cabinet Opening: FSHC-12W – 22"W x 41"H (559 x 1041 mm).
FSHC-17W – 22"W x 59"H (559 x 1499 mm).

SPECIFICATIONS

Model	Type*	Rack Style	Shipping Weight
FSHC-12W1	1 Door	Adjustable Angle Slides [▲]	265 lbs. (120 kg)
FSHC-12W2	2 Doors Pass-Through	Adjustable Angle Slides [▲]	295 lbs. (134 kg)
FSHC-17W1	1 Door	Adjustable Angle Slides [▲]	295 lbs. (134 kg)
FSHC-17W1D	1 Opening 2 Dutch Doors	Adjustable Angle Slides [▲]	305 lbs. (138 kg)
FSHC-17W2	2 Doors Pass-Through	Adjustable Angle Slides [▲]	325 lbs. (147 kg)
FSHC-17W2D	4 Dutch Doors Pass-Through	Adjustable Angle Slides [▲]	340 lbs. (154 kg)

* Full view Lexan® doors with full perimeter gaskets.

▲ 12 slides on each side standard. Additional slides available. Sheet Pans not included.

• 17 slides on each side standard. Additional slides available. Sheet Pans not included.

VOLTAGE

120 volts, 60 Hz, 1750 watts, 14.6 amps (NEMA 5-15P, NEMA 5-20P – Canada). Export voltages available, see specification sheet.

CORD LOCATION

Facing controls, right-hand side panel, lower right corner.

WATER TANK CAPACITY

2 gallons (8 liters).

WATER QUALITY REQUIREMENTS

Water supply in excess of 3.0 grains of hardness per gallon (GPG) (.75 grains of hardness per liter) must be treated and softened before being used. Water containing over 3.0 GPG (.75 GPL) will decrease the efficiency and reduce the operating life of the unit.

Note: Product failure caused by liming or sediment buildup is not covered under warranty.

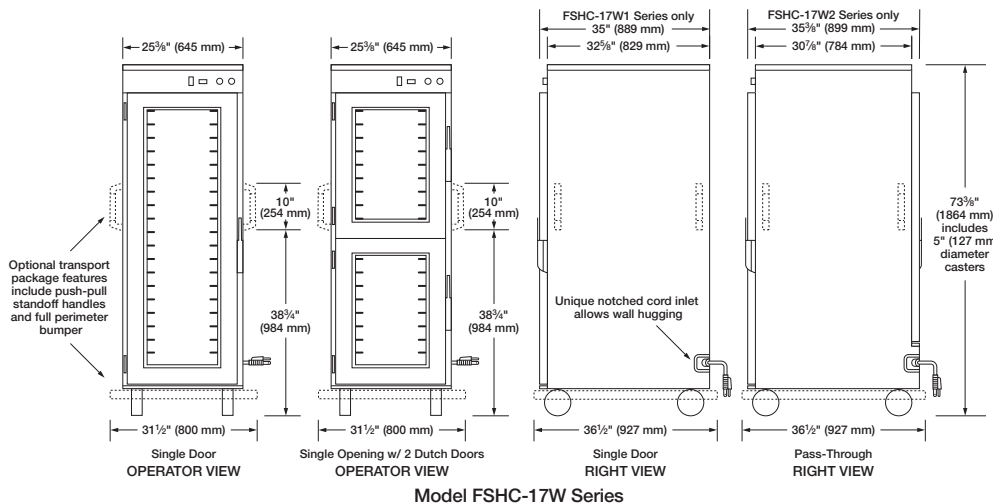

PORTABLE

NON-HUMIDIFIED HOLDING & DISPLAY CABINETS

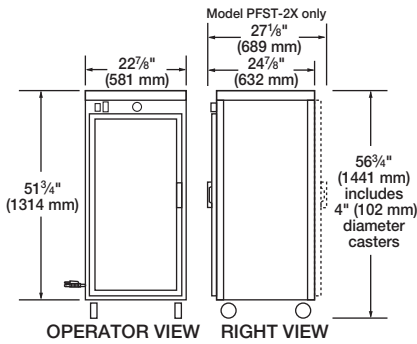

Model PFST-2X with 8-shelf rack



DIMENSIONS

Cabinet Opening: 18 3/4"W x 40 1/2"H (476 x 1029 mm).
 Available Shelf Space: 17 7/8"W x 17 7/8"D (454 x 454 mm).

SPECIFICATIONS

Model	Type	Shipping Weight
PFST-1X	1 Door	178 lbs. (81 kg)
PFST-2X	2 Doors	178 lbs. (81 kg)

VOLTAGE

120 volts, 1740 watts, 14.5 amps (NEMA 5-15P, NEMA 5-20P – Canada).

Export voltages available, see specification sheet.

CORD LOCATION

Facing controls, left-hand side panel, lower right corner.

PFST

FLAV-R-SAVOR® TALL NON-HUMIDIFIED HOLDING CABINETS

It's a great time to build your sales volume with the Flav-R-Savor Non-Humidified Tall Holding Cabinet. With capacity for up to 16 boxed or 8 bagged pizzas, you'll have the tools in place to give your customers hot and fresh carryout and delivery pizza.

- Excellent visibility to assure proper delivery rotation
- Illuminated cabinet interior for easy viewing
- Returns to temperature quickly after opening doors to keep pizza hot



PLUG CONFIGURATIONS

Model	120 Volt 60 Hz	120/208 Volt 60 Hz	208 Volt 60 Hz	240 Volt 60 Hz	220 Volt 50/60 Hz	240 Volt 50/60 Hz
FSD/FSDT	NEMA 5-15P	-	-	-	CEE 7/7 Schuko	BS-1363
FDW	NEMA 5-15P	-	-	-	CEE 7/7 Schuko	BS-1363
MDW	NEMA 5-15P	-	-	-	-	-
WFST	NEMA 5-15P*	-	-	-	CEE 7/7 Schuko	BS-1363
LFST	-	NEMA L14-20P	-	-	-	-
MN	NEMA 5-15P	-	-	-	CEE 7/7 Schuko	BS-1363
FSHAC/FSHACH	-	NEMA L14-20P	-	-	-	-
FSHAC-2PT	-	NEMA L14-20P	NEMA L6-20P	NEMA L6-20P	-	-
FSHACH-2PT	-	NEMA L14-30P	NEMA L6-30P	-	-	-
FSHC	NEMA 5-15P*	-	-	-	CEE 7/7 Schuko	BS-1363
PFST	NEMA 5-15P*	-	-	-	CEE 7/7 Schuko	BS-1363

* NEMA 5-20P for Canada Colored areas indicate models for export use only.

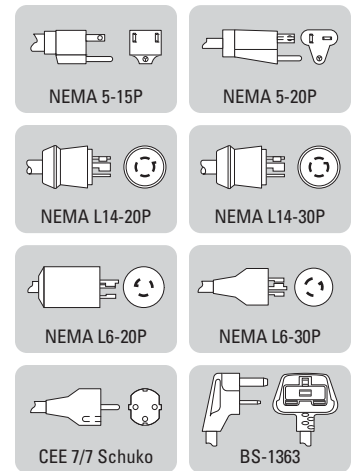

Unique Needs, Exact Solutions.

At Hatco we look, listen, and bring our full experience to your operation. "Customerization" is our brand promise...providing you with foodservice innovations that build your profits. That's Hatco, and that's always good for business.

Contact us today for all of your foodservice equipment needs.



Nothing less than the best.™

P.O. Box 340500
 Milwaukee, WI 53234-0500 USA
 (800) 558-0607 (414) 671-6350
 www.hatcocorp.com
 E-mail: equipsales@hatcocorp.com

Printed in U.S.A.



Form No. HDCB-0407-1 HC-CG
 Revised July 2008