



GLO-RAY® INFRARED FOODWARMER APPLICATION INFORMATION

Hatco Glo-Ray® Infrared Foodwarmers are available in a variety of sizes and combinations to fit holding areas of any length or depth. Some of the installation possibilities are described on this sheet. For more application information contact your local Representative or the Hatco Corporation.

AVAILABLE SIZES

WIDTH: *Aluminum Housing* — 18"-12' (457-3,658 mm). Available in 6" (152 mm) increments — single extrusion. *Stainless Steel Housing* — 24", 36", 48", 60", 72", and 96" (610, 914, 1219, 1524, 1829, and 2438 mm) only.

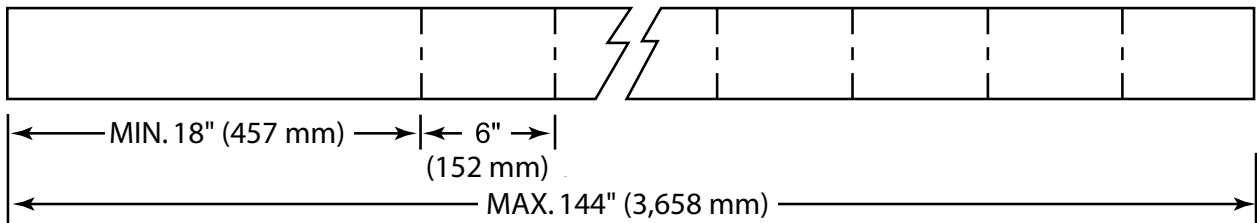

DEPTH: *Aluminum* — 6" or 9" (152 or 229 mm) or combinations using 3" or 6" (76 or 152 mm) spacers. *Stainless Steel* — 6" (15 cm) only.

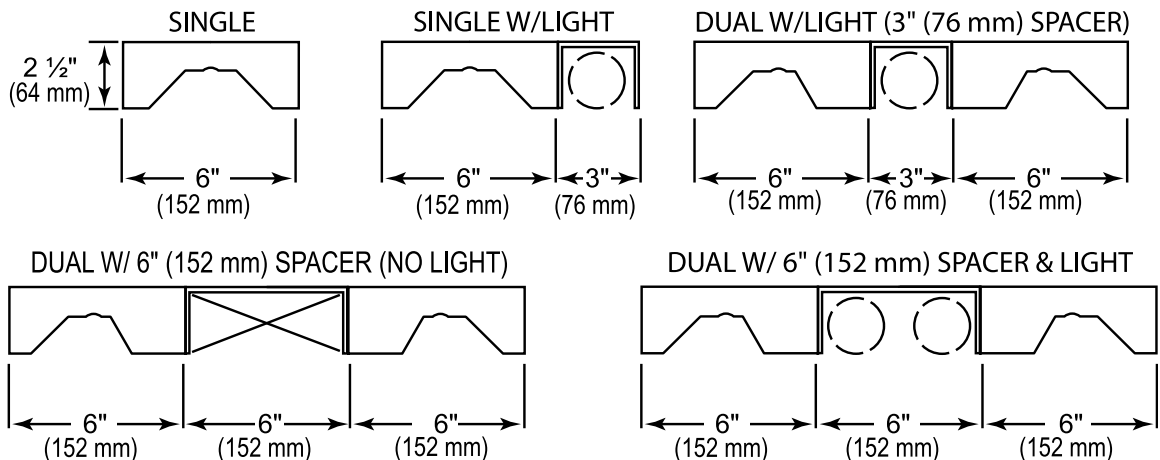

Incandescent lights are available for aluminum models only and can be ordered on either side of unit. Center lights recommended for dual warmer mounting. The 60-watt incandescent shatter-resistant bulbs provide illumination only and feature a special coating that guards against injury and food contamination in the event of breakage.

HEAT PATTERNS

PRE-FOCUSED: The Hatco Glo-Ray® radiating reflector directs infrared heat from the element to the holding area recommended. Mounting heights vary depending on the type of heating element.

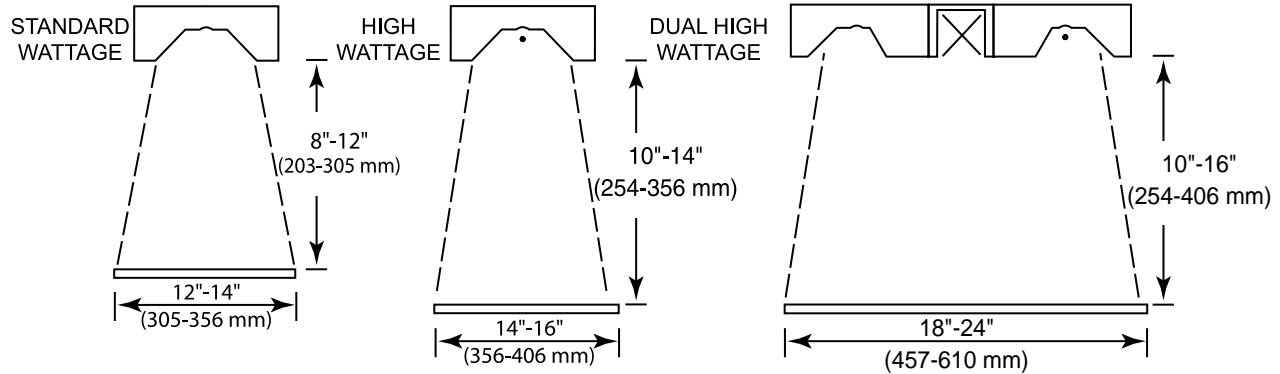

Optional slant reflectors are available to direct the heat pattern left or right.

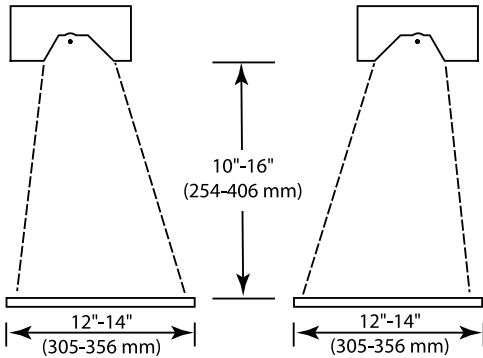

Available for both standard and high wattage elements.

CAUTION:

Do not install Glo-Ray® warmers less than **10" (635 mm) ABOVE NON-METALLIC SURFACE** when using standard wattage elements or **13" (330 mm) ABOVE NON-METALLIC SURFACE** with high wattage elements.

Dual warmers must be at least **30" (762 mm) ABOVE NON-METALLIC SURFACES.**

DO NOT INSTALL CLOSER THAN 3" (76 mm) BETWEEN WARMERS.

MOUNTING ARRANGEMENTS

BRACKETS: Standard hanger tabs are provided for undershelf, over shelf or chain installation. An optional angle bracket allows vertical adjustment that fits 6" or 9" (152 or 229 mm) housings.

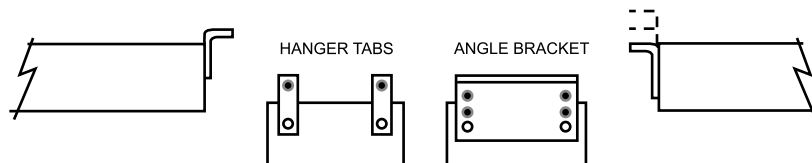

STANDS: A variety of optional stands are available for permanent and portable installation.

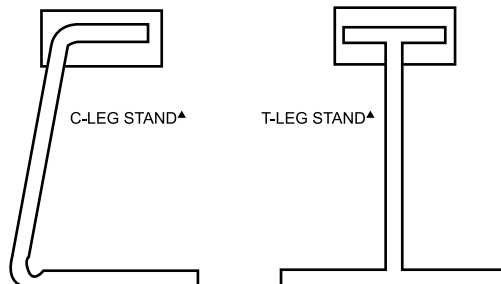

▲ Cord and Plug available for warmers with C-Leg or T-Leg stand. (Models 6" (1829 mm) or less.)

MOUNTING ARRANGEMENTS

ADJUSTABLE & NON-ADJUSTABLE TUBULAR STANDS*

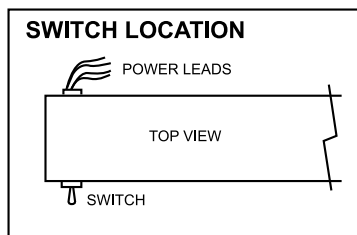
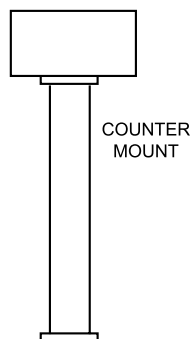

Standard location of switch and power leads. Alternate location available, consult factory.

*Two (2) sets of stands required when used with Dual Warmer installation.

UNDERSHELF: Hatco Glo-Ray® Foodwarmers *must* be mounted no less than 1½" (38 mm) below the underside of a turned-down shelf. If the warmer is mounted flush to the undershelf, the heat build-up will cause the wiring and switches to burn out – not covered under warranty.

The optional angle brackets are recommended for under-shelf installations. A remote location for the control switches is recommended and required for infinite switches.

PASS-THRU: If the pass-thru is 12" to 16" (305-406 mm) wide, the standard wattage or high wattage single unit can be used. For a 20" to 24" (508-610 mm) wide pass-thru shelf, a dual unit in either standard or high wattage is recommended. Duals must always have a minimum spacing of 3" (76 mm) between warmers.

When mounting a Foodwarmer over a surface other than stainless steel, consult the manufacturer regarding surface temperature limits before installing the warmer.

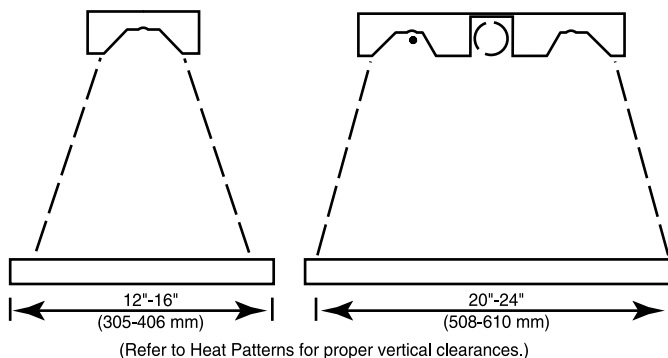
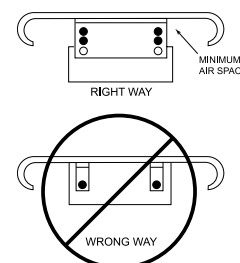

ELECTRICAL DATA

ELEMENTS: Available in standard or high wattage, from 18" up to 8' (457 to 2438 mm) in a single element. Glo-Ray models 108" through 144" (2743-3658 mm) contain tandem (end-to-end) elements individually controlled. **High temp wire (90°C minimum) must be used for power connections.**

SWITCHES: Glo-Ray Foodwarmers include an on-off toggle switch as standard. Consult factory on units with lights and dual warmers. Location of switch or switches and power connection can be specified, consult factory.

Infinite control is available to manually adjust heat output. **REMOTE INSTALLATION IS RECOMMENDED.** Glo-Ray is not moisture proof. A reduction in life of switch may result if not installed in a remote location.

REMOTE CONTROL ENCLOSURES:

Hatco Remote Control Enclosures are available for use with Glo-Ray infrared foodwarmers. All models are built in accordance with U.L. standards to include switches, indicator lights, and wiring, and are ready for installation. Available in four models: RMB-3 (5 ½" (140 mm)), RMB-7 (9" (229 mm)), RMB-14 (14" (356 mm)), and RMB-16 (16" (406 mm)).

Recommended for dual models or units with infinite switches. Consult factory for type and location of switches per enclosure.

VOLTAGE: Glo-Ray is available in 120, 208, 220, and 240 volts. Units with lights available in 120, 120/208 or 120/240, 220, or 240 volts. Models GRA-18 and GRAH-18, 120 volts only. Consult factory on units from 96" up to 144" (2438-3658 mm) in width.

**HATCO GLO-RAY® INFRARED FOODWARMERS
STANDARD WATT MODELS
ELECTRICAL RATINGS AND RECOMMENDATIONS**

SINGLE ELEMENT MODELS

| MODEL | VOLTS | WATTS | TOTAL AMPS | INFINITE SWITCH AVAILABLE |
|--------|-------|-------|------------|---------------------------|
| GRA-18 | 120 | 250 | 2.1 | YES |
| GRA-18 | 208 | 250 | 1.2 | YES |
| GRA-18 | 240 | 250 | 1.0 | YES |
| GRA-24 | 120 | 350 | 2.9 | YES |
| GRA-24 | 208 | 350 | 1.7 | YES |
| GRA-24 | 240 | 350 | 1.5 | YES |
| GRA-30 | 120 | 450 | 3.8 | YES |
| GRA-30 | 208 | 450 | 2.2 | YES |
| GRA-30 | 240 | 450 | 1.9 | YES |
| GRA-36 | 120 | 575 | 4.8 | YES |
| GRA-36 | 208 | 575 | 2.8 | YES |
| GRA-36 | 240 | 575 | 2.4 | YES |
| GRA-42 | 120 | 675 | 5.6 | YES |
| GRA-42 | 208 | 675 | 3.2 | YES |
| GRA-42 | 240 | 675 | 2.8 | YES |
| GRA-48 | 120 | 800 | 6.7 | YES |
| GRA-48 | 208 | 800 | 3.8 | YES |
| GRA-48 | 240 | 800 | 3.3 | YES |
| GRA-54 | 120 | 925 | 7.7 | YES |
| GRA-54 | 208 | 925 | 4.4 | YES |
| GRA-54 | 240 | 925 | 3.9 | YES |
| GRA-60 | 120 | 1050 | 8.8 | YES |
| GRA-60 | 208 | 1050 | 5.0 | YES |
| GRA-60 | 240 | 1050 | 4.4 | YES |
| GRA-66 | 120 | 1160 | 9.7 | YES† |
| GRA-66 | 208 | 1160 | 5.6 | YES |
| GRA-66 | 240 | 1160 | 4.8 | YES |
| GRA-72 | 120 | 1275 | 10.6 | YES† |
| GRA-72 | 208 | 1275 | 6.1 | YES |
| GRA-72 | 240 | 1275 | 5.3 | YES |
| GRA-84 | 120 | 1500 | 12.5 | YES† |
| GRA-84 | 208 | 1500 | 7.2 | YES |
| GRA-84 | 240 | 1500 | 6.3 | YES |
| GRA-96 | 120 | 1725 | 14.4 | YES† |
| GRA-96 | 208 | 1725 | 8.3 | YES |
| GRA-96 | 240 | 1725 | 7.2 | YES |

TANDEM ELEMENT MODELS

| | | | | |
|---------|-----|------|------|------------------|
| GRA-108 | 208 | 1850 | 8.9 | YES — 2 required |
| GRA-108 | 240 | 1850 | 7.7 | YES — 2 required |
| GRA-120 | 208 | 2100 | 10.1 | YES — 2 required |
| GRA-120 | 240 | 2100 | 8.8 | YES — 2 required |
| GRA-132 | 208 | 2320 | 11.2 | YES — 2 required |
| GRA-132 | 240 | 2320 | 9.7 | YES — 2 required |
| GRA-144 | 208 | 2550 | 12.3 | YES — 2 required |
| GRA-144 | 240 | 2550 | 10.6 | YES — 2 required |

† Infinite switches available only with tandem elements, two switches required.

NOTE: Remote installation is recommended for infinite controls.

Consult factory for special applications.

HATCO GLO-RAY® INFRARED FOODWARMERS
HIGH WATT MODELS
ELECTRICAL RATINGS AND RECOMMENDATIONS

SINGLE ELEMENT MODELS

| MODEL | VOLTS | WATTS | TOTAL AMPS | INFINITE SWITCH AVAILABLE |
|--------------|--------------|--------------|-------------------|----------------------------------|
| GRAH-18 | 120 | 350 | 2.9 | YES |
| GRAH-18 | 208 | 350 | 1.7 | YES |
| GRAH-18 | 240 | 350 | 1.5 | YES |
| GRAH-24 | 120 | 500 | 4.2 | YES |
| GRAH-24 | 208 | 500 | 2.4 | YES |
| GRAH-24 | 240 | 500 | 2.1 | YES |
| GRAH-30 | 120 | 660 | 5.5 | YES |
| GRAH-30 | 208 | 660 | 3.2 | YES |
| GRAH-30 | 240 | 660 | 2.8 | YES |
| GRAH-36 | 120 | 800 | 6.7 | YES |
| GRAH-36 | 208 | 800 | 3.8 | YES |
| GRAH-36 | 240 | 800 | 3.3 | YES |
| GRAH-42 | 120 | 950 | 7.9 | YES |
| GRAH-42 | 208 | 950 | 4.6 | YES |
| GRAH-42 | 240 | 950 | 4.0 | YES |
| GRAH-48 | 120 | 1100 | 9.2 | YES |
| GRAH-48 | 208 | 1100 | 5.3 | YES |
| GRAH-48 | 240 | 1100 | 4.6 | YES |
| GRAH-54 | 120 | 1250 | 10.4 | YES |
| GRAH-54 | 208 | 1250 | 6.0 | YES |
| GRAH-54 | 240 | 1250 | 5.2 | YES |
| GRAH-60 | 120 | 1400 | 11.7 | YES |
| GRAH-60 | 208 | 1400 | 6.7 | YES |
| GRAH-60 | 240 | 1400 | 5.8 | YES |
| GRAH-66 | 120 | 1560 | 13.0 | YES† |
| GRAH-66 | 208 | 1560 | 7.5 | YES |
| GRAH-66 | 240 | 1560 | 6.5 | YES |
| GRAH-72 | 120 | 1725 | 14.4 | YES† |
| GRAH-72 | 208 | 1725 | 8.3 | YES |
| GRAH-72 | 240 | 1725 | 7.2 | YES |
| GRAH-84 | 120 | 2050 | 17.1 | YES† |
| GRAH-84 | 208 | 2050 | 9.9 | YES |
| GRAH-84 | 240 | 2050 | 8.5 | YES |
| GRAH-96 | 120 | 2400 | 20.0 | YES† |
| GRAH-96 | 208 | 2400 | 11.5 | YES |
| GRAH-96 | 240 | 2400 | 10.0 | YES |

TANDEM ELEMENT MODELS

| | | | | |
|----------|-----|------|------|------------------|
| GRAH-108 | 208 | 2500 | 12.0 | YES — 2 required |
| GRAH-108 | 240 | 2500 | 10.4 | YES — 2 required |
| GRAH-120 | 208 | 2800 | 13.5 | YES — 2 required |
| GRAH-120 | 240 | 2800 | 11.7 | YES — 2 required |
| GRAH-132 | 208 | 3120 | 15.0 | YES — 2 required |
| GRAH-132 | 240 | 3120 | 13.0 | YES — 2 required |
| GRAH-144 | 208 | 3450 | 16.6 | YES — 2 required |
| GRAH-144 | 240 | 3450 | 14.4 | YES — 2 required |

† Infinite switches available only with tandem elements, two switches required.

NOTE: Remote installation is recommended for infinite controls.

Consult factory for special applications.

FOODWARMER APPLICATION WORKSHEET

GLO-RAY® INFRARED SPECIFICATIONS

Use diagram to assure proper specification of applicable unit

VOLTAGE (for heating elements)

| | |
|------|------|
| 120V | 208V |
| 220V | 240V |

WATTAGE

| | |
|----------|-----------|
| Standard | High Watt |
|----------|-----------|

(Consult factory for special wattages)

SWITCH(ES)

| | |
|--------|----------|
| Toggle | Infinite |
|--------|----------|

LIGHTS

(Lights will be 120V for US applications and 220V or 240V for export applications)

INDICATOR LIGHT

REMOTE CONTROL BOX

(Recommended for Dual models and Infinite Switch)

CORD & PLUG

(120V – 72" (1829 mm) unit or less with C-Leg or T-Leg stand only. Not available on Dual models.)

MOUNTING ARRANGEMENTS

C-Leg Stands* T-Leg Stands*

Non-Adjustable Tubular Stands (Specify length) _____ Other (Specify) _____

*Not available for Dual construction.

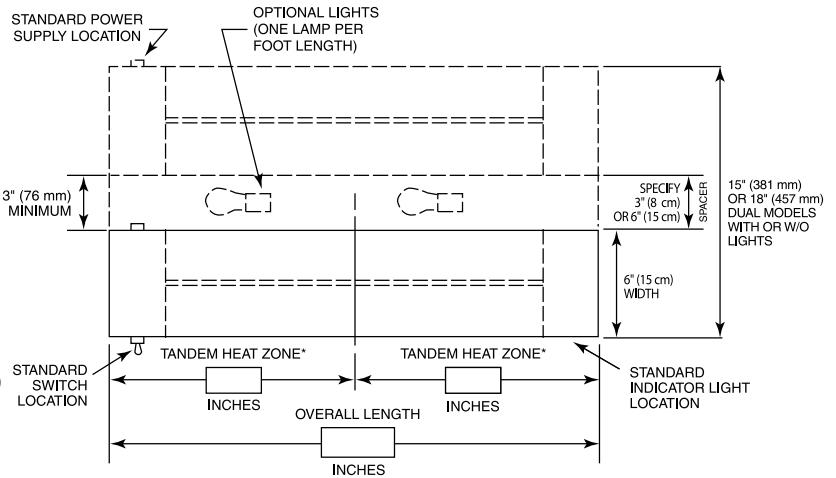

*Models 108" thru 144" (2743-3658 mm) use tandem elements. Tandem elements are optional on other models, consult factory.

INSTALLATION DETAILS

Use diagram to assure proper specification of applicable unit

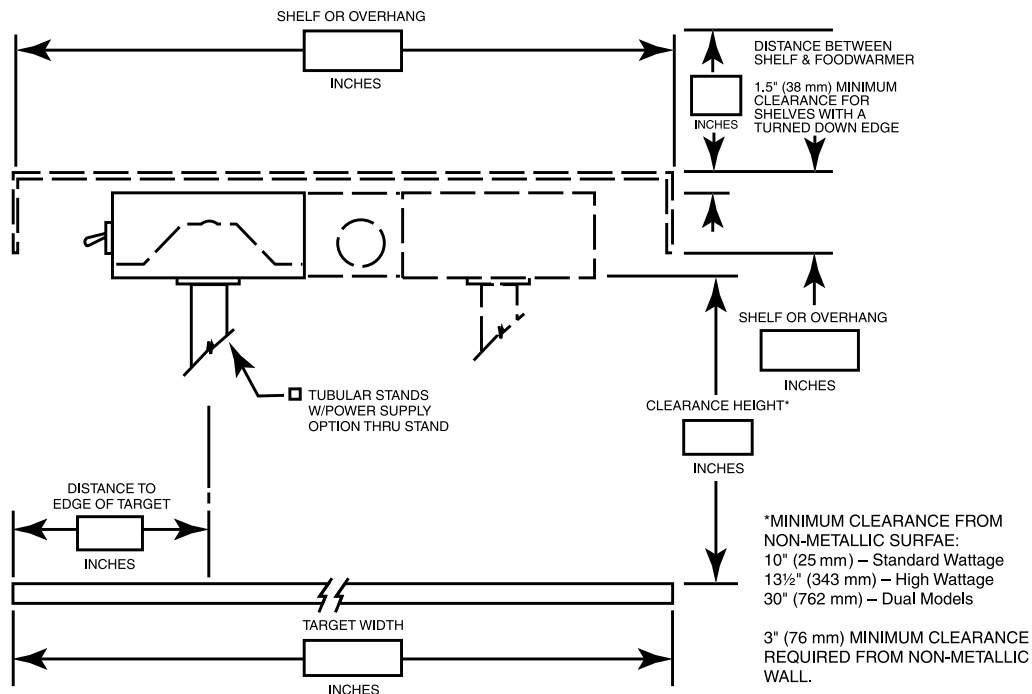

HATCO AUTHORIZED PARTS DISTRIBUTORS

ALABAMA

Jones McLeod Appl. Svc.
Birmingham 205-251-0159

ARIZONA

Auth. Comm. Food Equip.
Phoenix 602-234-2443
Byassee Equipment Co.
Phoenix 602-252-0402

CALIFORNIA

Industrial Electric
Huntington Beach 714-379-7100

Chapman Appl. Service
San Diego 619-298-7106

P & D Appliance
S. San Francisco 650-635-1900

COLORADO

Hawkins Commercial Appliance
Englewood 303-781-5548

DELAWARE

Food Equipment Service
Wilmington 302-996-9363

FLORIDA

Whaley Foodservice Repair
Jacksonville 904-725-7800

Universal Restaurant Services
Miami 305-593-5488

Nass Service Co., Inc.
Orlando 407-425-2681

B.G.S.I.
Pompano Beach 954-971-0456

Comm. Appliance Service
Tampa 813-663-0313

GEORGIA

TWC Services
Smyrna 770-438-9797

Heritage Service Group
Norcross 866-388-9837

Southeastern Rest. Svc.
Norcross 770-446-6177

HAWAII

Burney's Comm. Service, Inc.
Honolulu 808-848-1466

Food Equip Parts & Service
Honolulu 808-847-4871

ILLINOIS

Parts Town
Lombard 708-865-7278

Eichenauer Elec. Service
Decatur 217-429-4229

Midwest Elec. Appl. Service
Elmhurst 630-279-8000

Cone's Repair Service
Moline 309-797-5323

INDIANA

GCS Service
Indianapolis 317-545-9655

IOWA

Electric Motor Service Co.
Davenport 319-323-1823

Goodwin Tucker Group
Des Moines 515-262-8308

KENTUCKY

GCS Service
Louisville 502-367-1788

LOUISIANA

Chandlers Parts & Service
Baton Rouge 225-272-6620

MARYLAND

Electric Motor Service
Baltimore 410-467-8080

GCS Service
Silver Spring 301-585-7550

MASSACHUSETTS

Ace Service Co., Inc.
Needham 781-449-4220

MICHIGAN

Commercial Kitchen Service
Bay City 517-893-4561

Bildons Appliance Service
Detroit 248-478-3320

Midwest Food Equip. Service
Grandville 616-261-2000

MINNESOTA

GCS Service
Minneapolis 612-546-4221

MISSOURI

General Parts
Kansas City 816-421-5400

Commercial Kitchen Services
St. Louis 314-890-0700

Kaemmerlen Parts & Service
St. Louis 314-535-2222

NEBRASKA

Anderson Electric
Omaha 402-341-1414

NEVADA

Burney's Commercial
Las Vegas 702-736-0006

Hi. Tech Commercial Service
N. Las Vegas 702-649-4616

NEW JERSEY

Jay Hill Repair
Fairfield 973-575-9145

Service Plus
Flanders 973-691-6300

NEW YORK

Acme American Repairs, Inc.
Brooklyn 718-456-6544

Alpro Service Co.
Brooklyn 718-386-2515

Appliance Installation
Buffalo 716-884-7425

Northern Parts Dist.
Plattsburgh 518-563-3200

J.B. Brady, Inc.
Syracuse 315-422-9271

NORTH CAROLINA

Authorized Appliance
Charlotte 704-377-4501

OHIO

Akron/Canton Comm. Svc. Inc.
Akron 330-753-6635

Certified Service Center
Cincinnati 513-772-6600

Commercial Parts and Service
Columbus 614-221-0057

Electrical Appl. Repair Service
Independence 216-459-8700

E. A. Wichman Co.
Toledo 419-385-9121

OKLAHOMA

Hagar Rest. Service, Inc.
Oklahoma City 405-235-2184

Krueger, Inc.
Oklahoma City 405-528-8883

OREGON

Bressie Electric Co.
Portland 503-231-7171

Ron's Service, Inc.
Portland 503-624-0890

PENNSYLVANIA

Elmer Schultz Services
Philadelphia 215-627-5401

FAST Comm. Appl. Service
Philadelphia 215-288-4800

GCS Service
Pittsburgh 412-787-1970

K & D Service Co.
Harrisburg 717-236-9039

Electric Repair Co.
Reading 610-376-5444

RHODE ISLAND

Marshall Electric Co.
Providence 401-331-1163

SOUTH CAROLINA

Whaley Foodservice Repair
W. Columbia 803-791-4420

TENNESSEE

Camp Electric
Memphis 901-527-7543

TEXAS

Stove Parts Supply
Fort Worth 817-831-0381

Armstrong Repair Service
Houston 713-666-7100

Commercial Kitchen Repair Co.
San Antonio 210-735-2811

UTAH

La Monica's Rest. Equip. Service
Murray 801-263-3221

VIRGINIA

Daubers
Norfolk 757-855-4097

Daubers
Springfield 703-866-3600

WASHINGTON

Restaurant Appl. Service
Seattle 206-524-8200

WISCONSIN

A.S.C., Inc.
Madison 608-246-3160

A.S.C., Inc.
Milwaukee 414-543-6460

CANADA

BRITISH COLUMBIA

Key Food Equipment Service
Vancouver 604-433-4484

MANITOBA

Denko Mechanical Ltd.
Winnipeg 204-233-8003

ONTARIO

R.G. Henderson Ltd.
Toronto 416-422-5580

Choquette CKS
Ottawa 613-739-8458

QUEBEC

Choquette CKS
Montreal 514-722-2000

Choquette CKS
Québec City 418-681-3944

HATCO CORPORATION

P.O. Box 340500, Milwaukee, WI 53234-0500 U.S.A.

(800) 558-0607 (414) 671-6350

Parts & Service Fax (800) 690-2966 Int'l. Fax (414) 671-3976

www.hatcocorp.com