



Original Instructions
原始说明

GLOMAX[®]

Curved Infrared Strip Heaters

弧形长条形保温灯

GM5AH and GM5AHL Series/系列

Installation and Operating Manual

安装及操作手册

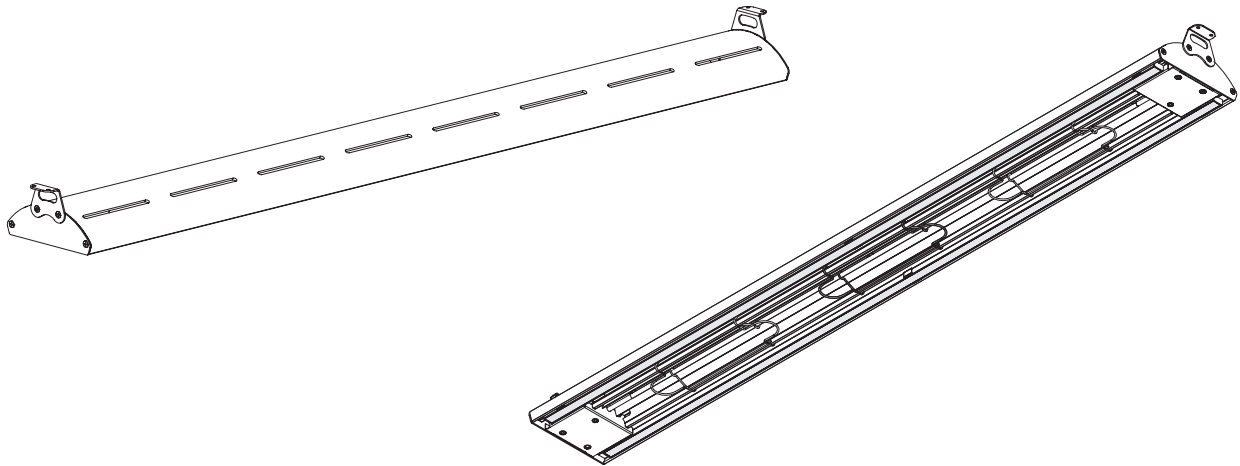

⚠ WARNING

Do not operate this equipment unless you have read and understood the contents of this manual! Failure to follow the instructions contained in this manual may result in serious injury or death. This manual contains important safety information concerning the maintenance, use, and operation of this product. If you're unable to understand the contents of this manual, please bring it to the attention of your supervisor. Keep this manual in a safe location for future reference.

English = p 2

⚠ 警告

请在认真阅读并理解本手册的内容后再操作本设备！不按照本手册中的说明操作可能会导致严重的人身伤亡事故。本手册中包含了有关本产品维护、使用和操作的重要安全事项。如果您不理解本手册的内容，请将本手册交给主管人员，以提请其注意。请将本手册妥善放置，以便参照。

中文 = 第 15 页

Important Owner Information	2	Operation	10
Introduction	2	General.....	10
Important Safety Information	3	Maintenance	10
Model Description	4	General.....	10
Model Designation	4	Daily Cleaning.....	10
Specifications	4	Replacing a Display Light.....	10
Plug Configurations.....	4	Troubleshooting Guide	11
Electrical Ratings Charts.....	5	Options and Accessories	12
Dimensions — Strip Heater.....	6	Service Information	13
Dimensions — Control Boxes.....	6	International Limited Warranty	14
Installation	6		
General.....	6		
Installation Site Requirements.....	7		
Installing the Unit.....	7		
Installing a Vertical Surface Mounted Control Box.....	8		
Installing an Under Shelf Mounted Control Box.....	9		

IMPORTANT OWNER INFORMATION

Record the model number, serial number, voltage, and purchase date of your unit in the spaces below (specification label located on the underside of the unit). Please have this information available when calling Hatco for service assistance.

Model No. _____

Serial No. _____

Voltage _____

Date of Purchase _____

Business Hours: 9:00 AM to 6:00 PM (Beijing Time)

Monday through Friday

Telephone: (0512) 6732-5091

E-mail: infocn@hatcocorp.com

Additional information can be found by visiting our web sites at:

www.hatcocorp.com

www.hatcocorp.cn

INTRODUCTION

Hatco GLOMAX® Curved Infrared Strip Heaters keep hot foods at optimum serving temperatures longer. The sleek, curved design minimizes the strip heaters size while accenting and warming the food product below. Specially designed reflectors direct the heat from the element to safely maintain peak serving temperatures longer without cooking the food beyond the point of excellence. GLOMAX Curved Strip Heaters are perfect for front-of-the-house applications such as buffet and serving lines.

GLOMAX Curved Infrared Strip Heaters are products of extensive research and field testing. The materials used were selected for maximum durability, attractive appearance, and optimum performance. Every unit is inspected and tested thoroughly prior to shipment.

This manual provides the installation, safety, and operating instructions for GLOMAX Curved Infrared Strip Heaters. Hatco recommends all installation, operating, and safety instructions appearing in this manual be read prior to installation or operation of a unit.

Safety information that appears in this manual is identified by the following signal word panels:



WARNING indicates a hazardous situation which, if not avoided, could result in death or serious injury.



CAUTION indicates a hazardous situation which, if not avoided, could result in minor or moderate injury.



NOTICE is used to address practices not related to personal injury.

NOTE: Refer to the Symbol Identification tables on the back cover of this manual for definitions of symbols that may appear in this manual.



Read the following important safety information before using this equipment to avoid serious injury or death and to avoid damage to equipment or property.

⚠ WARNING

ELECTRIC SHOCK HAZARD:

- Plug unit into a properly grounded electrical receptacle of the correct voltage, size, and plug configuration. If plug and receptacle do not match, contact a qualified electrician to determine and install proper voltage and size electrical receptacle.
- The Vertical Surface Mounted Control box must be mounted in a vertical surface. Mounting this control box in a horizontal surface may result in the collection of liquids and lead to electric shock.
- Turn OFF power switch, unplug power cord/turn off power at circuit breaker, and allow unit to cool before performing any cleaning, adjustments, or maintenance.
- DO NOT submerge or saturate with water. Unit is not waterproof. Do not operate if unit has been submerged or saturated with water.
- This unit is not “jet-proof” construction. Do not use jet-clean spray to clean this unit.
- Do not steam clean or use excessive water on unit.
- Do not attempt to repair or replace a damaged power cord. The cord must be replaced by Hatco, an Authorized Hatco Service Agent, or a person with similar qualifications.
- Use only Genuine Hatco Replacement Parts when service is required. Failure to use Genuine Hatco Replacement Parts will void all warranties and may subject operators of the equipment to hazardous electrical voltage, resulting in electrical shock or burn. Genuine Hatco Replacement Parts are specified to operate safely in the environments in which they are used. Some after-market or generic replacement parts do not have the characteristics that will allow them to operate safely in Hatco equipment.

FIRE HAZARD:

- Do not install units above or around combustible surfaces. Discoloration or combustion could occur. Units must be installed in non-combustible surroundings only.
- Do not install strip heaters less than 254 mm (10”) above non-combustible surfaces. If safe distances are not maintained, discoloration or combustion could occur.

EXPLOSION HAZARD: Do not store or use gasoline or other flammable vapors or liquids in the vicinity of this or any other appliance.

Make sure all operators have been instructed on the safe and proper use of the unit.

This unit is not intended for use by children or persons with reduced physical, sensory, or mental capabilities. Ensure proper supervision of children and keep them away from the unit.

⚠ WARNING

Use only Hatco-approved LED light assemblies that are designed specifically for food holding areas. Using LED light assemblies not designed for food holding areas could result in personal injury and/or food contamination.

Make sure food product has been heated to the proper food-safe temperature before placing in unit. Failure to heat food product properly may result in serious health risks. This unit is for holding pre-heated food product only.

This unit has no “user-serviceable” parts. If service is required on this unit, contact an Authorized Hatco Service Agent or contact the Hatco Service Department at (0512) 6732-5091.

⚠ CAUTION

BURN HAZARD: Some exterior surfaces on the unit will get hot. Use caution when touching these areas.

Standard and approved manufacturing oils may smoke up to 30 minutes during initial startup. This is a temporary condition. Operate unit without food product until smoke dissipates.

To ensure safe and proper operation, refer to “Installation Site Requirements” in the INSTALLATION section of this manual.

NOTICE

Units are voltage-specific. Refer to specification label for electrical requirements before beginning installation.

Do not add a decorative soffit to hide a pass-through mounted strip heater. Excessive heat can cause unit failure.

Install remote-mounted control box outside of areas subject to temperatures above 40°C (104°F). Excessive temperatures will cause controls to overheat, malfunction, and fail.

Damage to any countertop material caused by heat generated from Hatco equipment is not covered under the Hatco warranty. Contact the manufacturer of the countertop material for application information.

Use non-abrasive cleaners and cloths only. Abrasive cleaners and cloths could scratch the finish of the unit, marring its appearance and making it susceptible to soil accumulation.

Do not locate unit in area with excessive air movement around unit. Avoid areas that may be subject to active air movements or currents (i.e., near exhaust fans/hoods, air conditioning ducts, and exterior doors).

MODEL DESCRIPTION



All Models

All GLOMAX® Curved Infrared Strip Heaters consist of a curved, aluminum housing that is ideal for installation in tight spaces. A pre-focused heat pattern directs heat from a tubular element to bathe the entire holding surface below. Curved Infrared Strip Heaters are available in widths of 610–1982 mm (24”–78”). Finish options include clear anodized and black anodized.

Curved Infrared Strip Heaters are supplied with angle brackets for under-shelf mounting and a 1.5 m (5') power cord and plug.

NOTE: Refer to the OPTIONS AND ACCESSORIES section for countertop mounting options and installation.

GM5AH Models

These models are heat only. The controls are housed in a remote-mounted control box and include an Infinite Heat Control and a Power Indicator Light.

GM5AHL Models

In addition to heat, these models include two LED light strips that provide warm white lighting (3050 K) to accent the food product below. The controls are housed in a remote-mounted control box and include an Infinite Heat Control, a Power Indicator Light, and a Lights I/O (on/off) Switch.

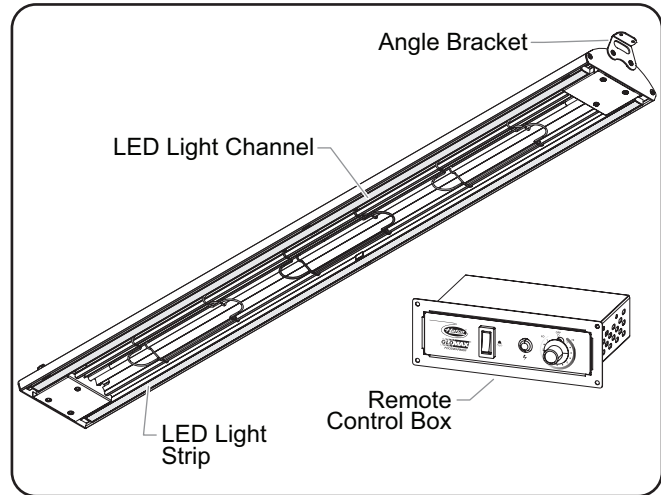

GM5AHL Series Strip Heater

MODEL DESIGNATION

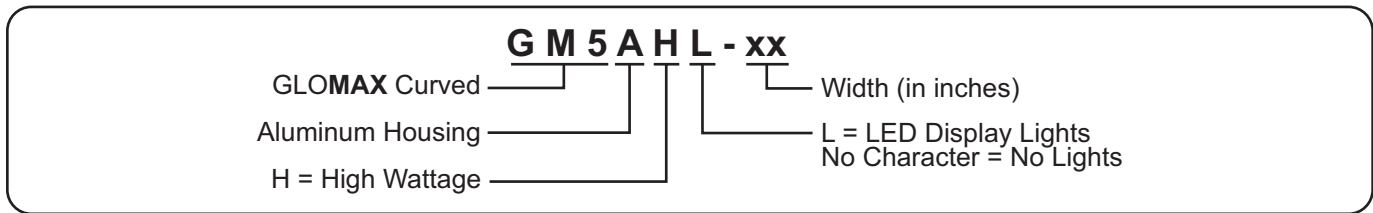

SPECIFICATIONS

Plug Configuration

Units are supplied from the factory with an electrical cord and plug installed. Plugs are supplied according to the application.



ELECTRIC SHOCK HAZARD: Plug unit into a properly grounded electrical receptacle of the correct voltage, size, and plug configuration. If plug and receptacle do not match, contact a qualified electrician to determine and install proper voltage and size electrical receptacle.

NOTE: Receptacle not supplied by Hatco.

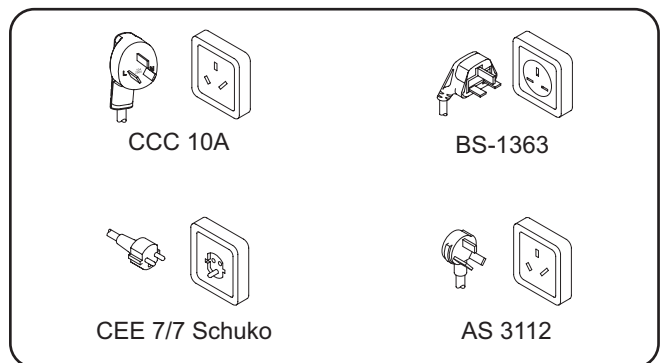

Plug Configuration

NOTE: The specification labels are located on the underside of the unit. See the label for the serial number and verification of unit electrical information.

Electrical Ratings Chart — GM5AH Models

Model	Voltage (V)	Watts (W)	Amps (A)	Plug Configuration	Shipping Weight
GM5AH-24	220–230	500–546	2.3–2.4	CCC 10A, BS-1363, CEE 7/7 Schuko, AS 3112	5 kg (10 lbs.)
	230–240	495–500	1.9–2.1		
GM5AH-30	220–230	660–721	3.0–3.1	CCC 10A, BS-1363, CEE 7/7 Schuko, AS 3112	5 kg (11 lbs.)
	230–240	606–660	2.6–2.8		
GM5AH-36	220–230	800–874	3.6–3.8	CCC 10A, BS-1363, CEE 7/7 Schuko, AS 3112	6 kg (13 lbs.)
	230–240	735–800	3.2–3.3		
GM5AH-42	220–230	950–1038	4.3–4.5	CCC 10A, BS-1363, CEE 7/7 Schuko, AS 3112	7 kg (15 lbs.)
	230–240	872–950	3.8–4.0		
GM5AH-48	220–230	1100–1202	5.0–5.2	CCC 10A, BS-1363, CEE 7/7 Schuko, AS 3112	7 kg (16 lbs.)
	230–240	1010–1100	4.4–4.6		
GM5AH-54	220–230	1250–1366	5.7–5.9	CCC 10A, BS-1363, CEE 7/7 Schuko, AS 3112	8 kg (18 lbs.)
	230–240	1148–1250	5.0–5.2		
GM5AH-60	220–230	1400–1530	6.4–6.7	CCC 10A, BS-1363, CEE 7/7 Schuko, AS 3112	8 kg (18 lbs.)
	230–240	1286–1400	5.4–5.8		
GM5AH-66	220–230	1560–1705	7.1–7.4	CCC 10A, BS-1363, CEE 7/7 Schuko, AS 3112	9 kg (19 lbs.)
	230–240	1433–1560	6.2–6.5		
GM5AH-72	220–230	1725–1885	7.8–8.2	CCC 10A, BS-1363, CEE 7/7 Schuko, AS 3112	10 kg (21 lbs.)
	230–240	1584–1725	6.6–7.2		
GM5AH-78	220–230	1890–2066	8.6–9.0	CCC 10A, BS-1363, CEE 7/7 Schuko, AS 3112	11 kg (24 lbs.)
	230–240	1736–1890	7.5–7.9		

Electrical Ratings Chart — GM5AHL Models

Model	Voltage (V)	Watts (W)	Amps (A)	Plug Configuration	Shipping Weight
GM5AHL-24	220–230	510–555	2.3–2.4	CCC 10A, BS-1363, CEE 7/7 Schuko, AS 3112	5 kg (12 lbs.)
	230–240	467–510	2.0–2.1		
GM5AHL-30	220–230	670–733	3.0–3.2	CCC 10A, BS-1363, CEE 7/7 Schuko, AS 3112	6 kg (13 lbs.)
	230–240	616–670	2.7–2.8		
GM5AHL-36	220–230	812–888	3.7–3.9	CCC 10A, BS-1363, CEE 7/7 Schuko, AS 3112	7 kg (15 lbs.)
	230–240	748–812	3.2–3.4		
GM5AHL-42	220–230	964–1053	4.4–4.6	CCC 10A, BS-1363, CEE 7/7 Schuko, AS 3112	7 kg (15 lbs.)
	230–240	885–964	3.8–4.0		
GM5AHL-48	220–230	1116–1220	5.1–5.3	CCC 10A, BS-1363, CEE 7/7 Schuko, AS 3112	8 kg (17 lbs.)
	230–240	1025–1116	4.5–4.7		
GM5AHL-54	220–230	1267–1384	5.8–6.0	CCC 10A, BS-1363, CEE 7/7 Schuko, AS 3112	9 kg (19 lbs.)
	230–240	1163–1267	5.1–5.3		
GM5AHL-60	220–230	1418–1550	6.4–6.7	CCC 10A, BS-1363, CEE 7/7 Schuko, AS 3112	9 kg (20 lbs.)
	230–240	1302–1418	5.7–5.9		
GM5AHL-66	220–230	1579–1726	7.2–7.5	CCC 10A, BS-1363, CEE 7/7 Schuko, AS 3112	10 kg (21 lbs.)
	230–240	1450–1579	6.3–6.6		
GM5AHL-72	220–230	1744–1907	7.9–8.3	CCC 10A, BS-1363, CEE 7/7 Schuko, AS 3112	10 kg (22 lbs.)
	230–240	1602–1744	7.0–7.3		
GM5AHL-78	220–230	1910–2088	8.7–9.1	CCC 10A, BS-1363, CEE 7/7 Schuko, AS 3112	11 kg (24 lbs.)
	230–240	1754–1910	7.6–8.0		

SPECIFICATIONS



Dimensions — Strip Heater

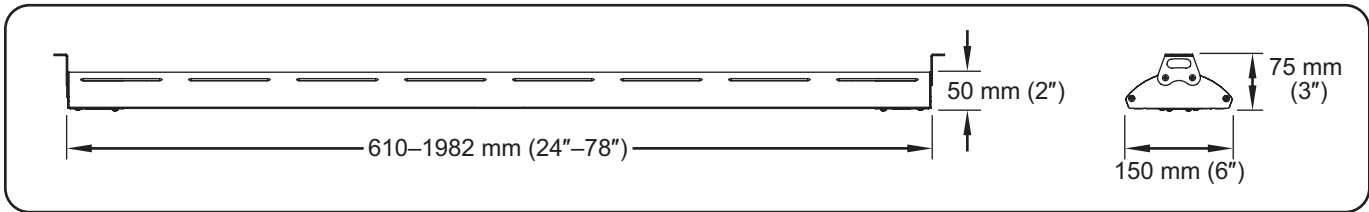

Dimensions — Control Boxes

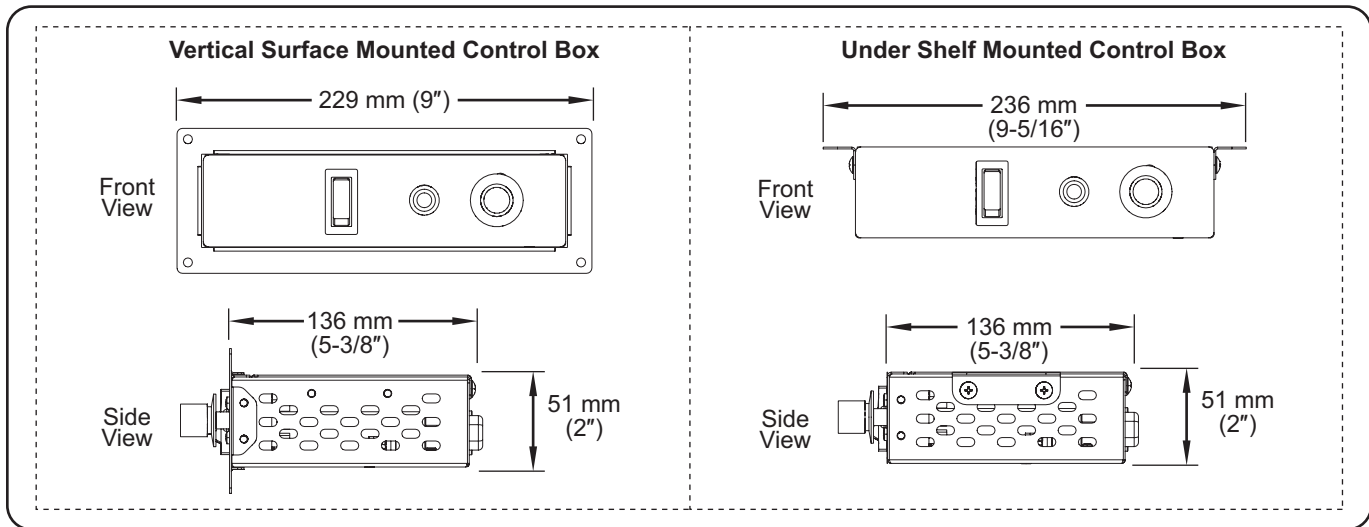

INSTALLATION

General

Use the information in this section to install a GLOMAX® Curved Infrared Strip Heater. Strip heaters are shipped with most components pre-assembled.



ELECTRIC SHOCK HAZARD: Plug unit into a properly grounded electrical receptacle of the correct voltage, size, and plug configuration. If plug and receptacle do not match, contact a qualified electrician to determine and install proper voltage and size electrical receptacle.

FIRE HAZARD:

- Do not install units above or around combustible surfaces. Discoloration or combustion could occur. Units must be installed in non-combustible surroundings only.
- Do not install strip heaters less than 254 mm (10") above non-combustible surfaces. If safe distances are not maintained, discoloration or combustion could occur.



To ensure safe and proper operation, refer to "Installation Site Requirements" in the INSTALLATION section of this manual.



Units are voltage-specific. Refer to specification label for electrical requirements before beginning installation.

Do not add a decorative soffit to hide a pass-through mounted strip heater. Excessive heat can cause unit failure.

Damage to any countertop material caused by heat generated from Hatco equipment is not covered under the Hatco warranty. Contact the manufacturer of the countertop material for application information.

NOTE: Contact the manufacturer of the countertop base material for application information and surface temperature limits before installing the unit.

1. Remove the unit and control box from the shipping cartons, and remove all packing materials.

NOTE: To prevent delay in obtaining warranty coverage, complete online warranty registration. See the IMPORTANT OWNER INFORMATION section for details.

2. Remove tape and protective packaging from all surfaces of the unit.

NOTE: For units equipped with tubular stands, refer to the OPTIONS AND ACCESSORIES section for installation details.

3. Install the unit in an appropriate location. Refer to "Installation Site Requirements" and the "Installing the Unit" procedure in this section.
 - Locate the unit in an area where the ambient air temperature is constant and a minimum of 21°C (70°F). Avoid areas that may be subject to active air movements or currents (i.e., near exhaust fans/hoods, air conditioning ducts, and exterior doors).
 - Verify that minimum clearance requirements and recommended mounting heights are met. Refer to "Installation Site Requirements" in this section.
 - Strip heaters can be installed over a steam table. Follow the standard minimum clearance requirements.
4. Install the remote control box in the desired location. Refer to "Installing a Vertical Surface Mounted Control Box" or "Installing an Under Shelf Mounted Control Box" in this section for detailed information.

Installation Site Requirements

The installation site must meet specific requirements for safe and proper installation of the unit.

- Make sure the countertop material is designed to withstand long periods of hot food holding temperatures. Contact the manufacturer of the countertop material for application information.
- Make sure the installation site provides the proper minimum clearances for adjacent surfaces.



FIRE HAZARD: Do not install units above or around combustible surfaces. Discoloration or combustion could occur. Units must be installed in non-combustible surroundings only.

Minimum Clearance Requirements—Non-Combustible Surroundings

Model	A	B	C
GM5AH and GM5AHL	254 mm (10")	0 mm (0")	25 mm (1")

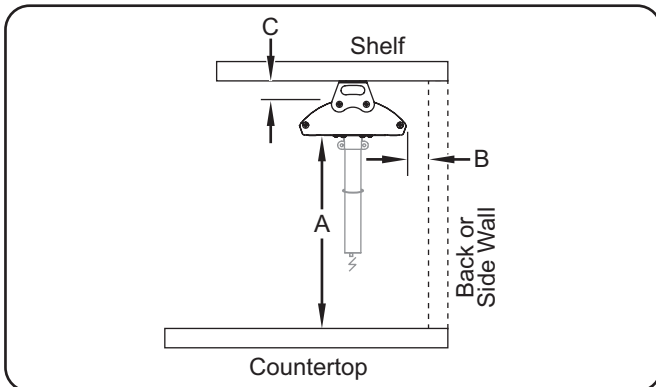

Minimum Clearances

NOTE: Strip heaters can be installed over a steam table. Follow the minimum clearance requirements.

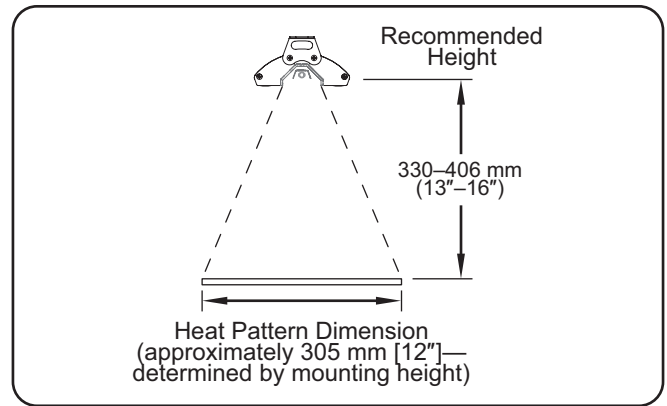

Recommended Element Height for the GM5AH Series in all widths
 NOTE: The size of heat pattern will vary depending on the height of the unit.

Installing the Unit

Use the following procedure to install the unit using the supplied angle brackets.

NOTE: Units come with a 1.5 m (5') power cord and plug.

NOTICE

Damage to any countertop material caused by heat generated from Hatco equipment is not covered under the Hatco warranty. Contact manufacturer of countertop material for application information.

1. Install the angle brackets onto the unit using the supplied screws.

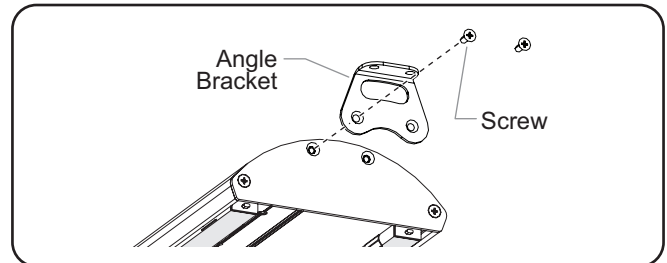

Angle Bracket Installation

2. Determine the exact mounting location on the underside of the shelf.

NOTE: The attached angle brackets provide 25 mm (1") clearance between the unit and an overshef.

NOTE: Units can be mounted to a flat shelf or a shelf with rolled/flanged edges. The unit must be installed with the minimum 25 mm (1") clearance measured from the lowest part of the overshef. For example, a shelf with a 25 mm (1") flanged edge would require the unit to be installed 51 mm (2") below the underside of the shelf. If minimum distances are not maintained, damage to the surroundings and/or failure to the unit could occur.

continued...

3. Fasten the angle brackets to the underside of the shelf using appropriate fasteners (not supplied by Hatco). Make sure the unit is facing the desired direction with the wire leads on the proper side before fastening the unit to the shelf.

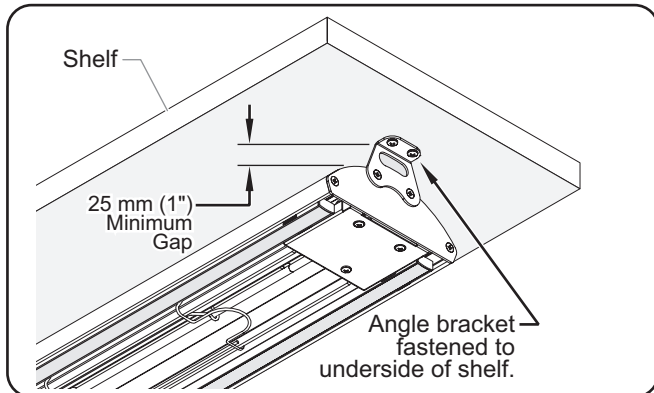

Flat Shelf Installation

4. Route the element wire leads and LED wire leads toward the installation location for the control box.

Installing a Vertical Surface Mounted Control Box

Use the following procedure to install the vertical surface mounted control box.



The Vertical Surface Mounted Control box must be mounted in a vertical surface. Mounting this control box in a horizontal surface may result in the collection of liquids and lead to electric shock.



Install remote-mounted control box outside of areas subject to temperatures above 40°C (104°F). Excessive temperatures will cause controls to overheat, malfunction, and fail.

IMPORTANT NOTE:

Remote-mounted control boxes and control switches must be installed in a cool, dry location as far away from any heat zone as possible. **Do not mount control boxes directly on, under, or above unit.** Do not mount control boxes in direct contact with any heated surface or near any steam generating equipment.

1. Cut and drill the appropriate holes in the vertical surface where the control box will be installed. Refer to the "Control Box Cutout and Screw Hole Dimensions" illustration for cutout and screw hole dimensions.

NOTE: Make sure the control box installation location provides enough space behind the vertical surface for the depth of the control box and electrical connections.

2. Route the element wire leads and the LED wire leads from the unit to the control box through the cutout and make electrical connections.
3. Plug the power cord into a properly grounded electrical receptacle of the correct voltage, size, and plug configuration. See the SPECIFICATIONS section for details.

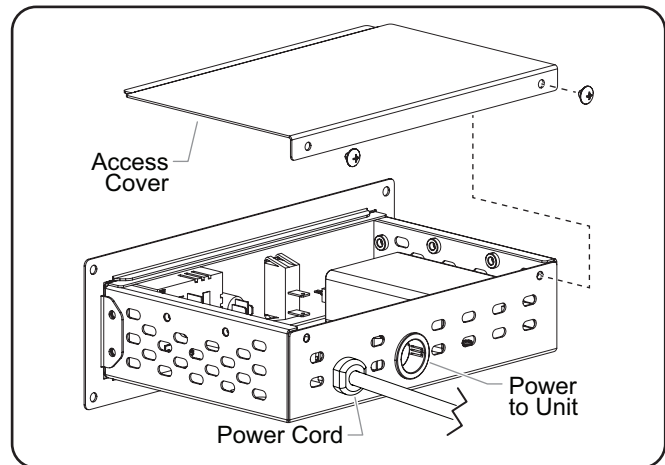

Vertical Surface Mounted Control Box Electrical Connections

4. Position the control box into the cutout opening through the front side. Make sure that none of the electrical wires are pinched or stressed.
5. Apply a 6 mm (1/4") bead of NSF-approved silicone sealant where the control box flange will contact the cabinet surface.
6. Fasten the control box to the vertical surface using four screws (not supplied).

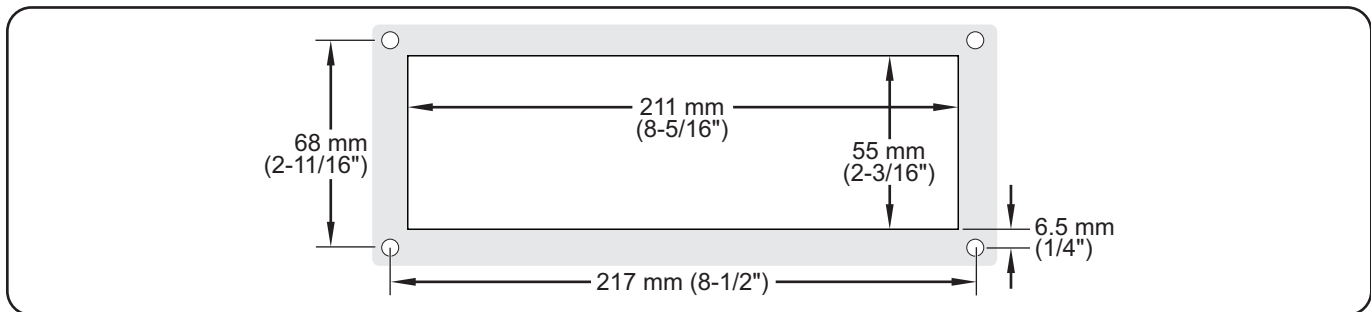

Control Box Cutout and Screw Hole Dimensions

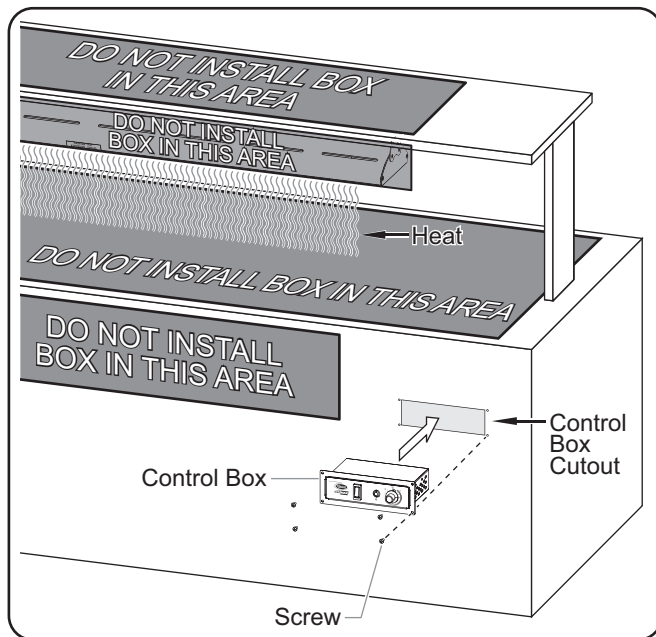

Installing the Vertical Surface Mounted Control Box

Installing an Under Shelf Mounted Control Box

Use the following procedure to install the under shelf mounted control box.

NOTICE

Install remote-mounted control box outside of areas subject to temperatures above 40°C (104°F). Excessive temperatures will cause controls to overheat, malfunction, and fail.

IMPORTANT NOTE:

Remote-mounted control boxes and control switches must be installed in a cool, dry location as far away from any heat zone as possible. **Do not mount control boxes directly on, under, or above unit.** Do not mount control boxes in direct contact with any heated surface or near any steam generating equipment.

1. Drill the appropriate holes in the surface where the control box will be installed, if necessary. Refer to the "Control Box Screw Hole Dimensions" illustration for screw hole dimensions.

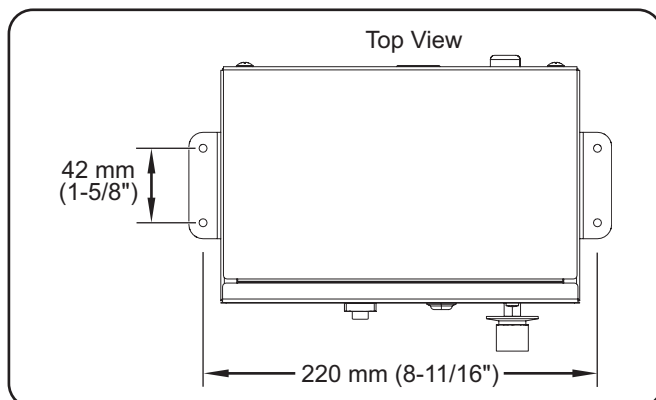

Control Box Screw Hole Dimensions

NOTE: Make sure the control box installation location provides enough space for the depth of the control box and electrical connections.

2. Route the element wire leads and the LED wire leads from the unit to the control box and make the electrical connections.
3. Plug the power cord into a properly grounded electrical receptacle of the correct voltage, size, and plug configuration. See the SPECIFICATIONS section for details.

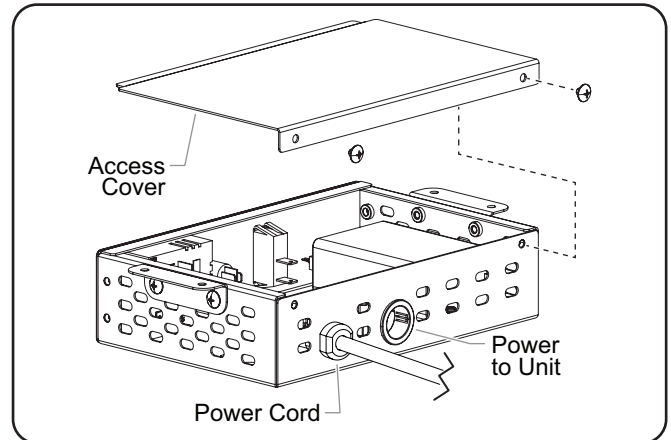

Under Shelf Mounted Control Box Electrical Connections

4. Position the control box into position under the horizontal surface. Make sure that none of the electrical wires are pinched or stressed.
5. Fasten the control box to the horizontal surface using four screws (not supplied).

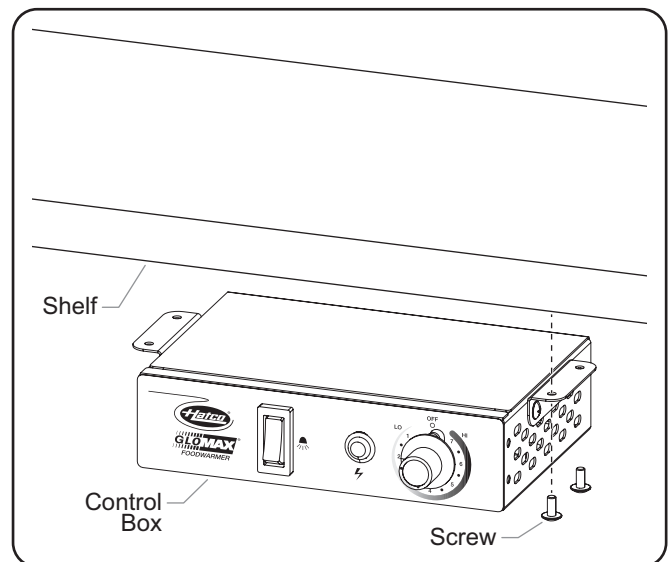

Installing the Under Shelf Mounted Control Box

OPERATION



General

GLOMAX® Curved Infrared Strip Heaters are designed for ease of operation. Use the following information and procedures to operate the unit.



Read all safety messages in the **IMPORTANT SAFETY INFORMATION** section before operating this equipment.



BURN HAZARD: Some exterior surfaces on unit will get hot. Use caution when touching these areas.

Standard and approved manufacturing oils may smoke up to 30 minutes during initial startup. This is a temporary condition. Operate unit without food product until smoke dissipates.

Controls

GM5AH and GM5AHL Series Curved Infrared Strip Heaters include a remote-mounted control box. The following is a list of the controls on the control box.

Infinite Heat Control—Turns power on and off to the heating elements as well as controls the heat output of the elements.

Lights I/O (on/off) Switch—Turns power on and off to the LED light strips (if equipped).

Power Indicator Light—Illuminates when power is on, and shuts off when power is off.

Startup

1. Turn on the strip heater.
 - Turn the Infinite Heat Control to the desired setting.
 - The indicator light will illuminate and the heating elements will energize.
2. Move the Lights I/O (on/off) Switch to the I (on) position, if equipped.
 - The LED light strips will illuminate (if equipped).
3. Allow 30 minutes to reach operating temperature before placing preheated food product underneath the strip heater.

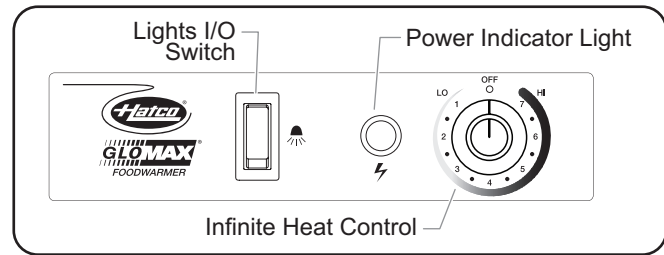

Control Box

Shutdown

1. Turn the Infinite Heat Control to the **O** (off) position.
 - The indicator light will shut off and the heating elements will shut down.
2. Move the Lights I/O (on/off) Switch to the **O** (off) position, if equipped. The LED lights will shut off (if equipped).

MAINTENANCE

General

GLOMAX Curved Infrared Strip Heaters are designed for maximum durability and performance with minimum maintenance.



ELECTRIC SHOCK HAZARD:

- Turn OFF power switch, unplug power cord/turn off power at circuit breaker, and allow unit to cool before performing any cleaning, adjustments, or maintenance.
- **DO NOT** submerge or saturate with water. Unit is not waterproof. Do not operate if unit has been submerged or saturated with water.
- This unit is not “jet-proof” construction. Do not use jet-clean spray to clean this unit.
- Do not steam clean or use excessive water on unit.
- Use only Genuine Hatco Replacement Parts when service is required. Failure to use Genuine Hatco Replacement Parts will void all warranties and may subject operators of the equipment to hazardous electrical voltage, resulting in electrical shock or burn. Genuine Hatco Replacement Parts are specified to operate safely in the environments in which they are used. Some after-market or generic replacement parts do not have the characteristics that will allow them to operate safely in Hatco equipment.

This unit has no “user-serviceable” parts. If service is required on this unit, contact an Authorized Hatco Service Agent or contact the Hatco Service Department at (0512) 6732-5091.

Daily Cleaning

To preserve the finish of the unit, it is recommended that all surfaces be cleaned daily.

NOTICE

Use non-abrasive cleaners and cloths only. Abrasive cleaners and cloths could scratch the finish of the unit, marring its appearance and making it susceptible to soil accumulation.

1. Turn off the unit, unplug the power cord, and allow the unit to cool.
2. Wipe down all metal surfaces with a water-dampened, non-abrasive cloth. Stubborn stains may be removed with a good stainless steel or non-abrasive cleaner. Clean hard to reach areas using a small brush and mild soap.
3. Wipe dry the entire unit using a non-abrasive, dry cloth.

Replacing a Display Light—GM5AHL Series

The display lights consist of two LED light strips that illuminate the warming area. These light strips have special covers to guard against injury and food contamination in the event of breakage.

Replacement of a LED light strip must be done by an Authorized Hatco Service Agent.

NOTE: Hatco LED light strips meet safety standards for food holding and display areas.



Use only Hatco-approved LED light assemblies that are designed specifically for food holding areas. Using LED light assemblies not designed for food holding areas could result in personal injury and/or food contamination.





This unit must be serviced by qualified personnel only. Service by unqualified personnel may lead to electric shock or burn.



ELECTRIC SHOCK HAZARD: Turn OFF power switch, unplug power cord/turn off power at circuit breaker, and allow unit to cool before performing any cleaning, adjustments, or maintenance.

Symptom	Probable Cause	Corrective Action
Unit is turned "On" but there is no heat.	No power to unit.	Check circuit breaker and reset as necessary.
	Switch is defective.	Contact Authorized Service Agent or Hatco for assistance.
	Wiring is open.	
	Heating element defective.	
Heat on but no lights (GM5AHL only).	LED assembly defective.	Contact Authorized Service Agent or Hatco for assistance.
	Faulty wiring.	
Heat is inadequate.	Unit mounted too high above target area.	Lower unit, putting effective heat closer to target.
	Excessive air movement around strip heater target area.	Restrict or redirect air movement (air conditioning duct or exhaust fan) away from unit.
	Incorrect power supply (low).	Check power supply to unit, making sure it matches rating on the unit. If power supply is incorrect, change to match rating on unit.
Heat is excessive.	Unit mounted too close to target area.	Check to see that installation is within specifications for type/model. Increase mounting height if too close.
	Voltage supply too high.	Check power supply to unit, making sure it matches rating on unit. If power supply is incorrect, change to match rating.
Control switches burn out.	Remote control box is mounted too close to the heat zone.	Move remote control box away from the heat zone. The maximum ambient temperature allowed for the control box is 40°C (104°F).
	Switches used are not Hatco supplied.	Genuine Hatco Parts are specified to operate safely and properly in the environment in which they are used. Contact Authorized Service Agent or Hatco to replace switches with Genuine Hatco Replacement Parts.

Troubleshooting Questions?

If you continue to have problems resolving an issue, please contact the nearest Authorized Hatco Service Agency or Hatco for assistance. To locate the nearest Service Agency, log onto the Hatco website at www.hatcocorp.com, select the *Support* pull-down menu, and click on "Find A Service Agent"; or contact the **Hatco Parts and Service Team** at:

Telephone: (0512) 6732-5091

e-mail: infocn@hatcocorp.com

Non-Adjustable Stands

Aluminum, non-adjustable 406 mm (16") stands are available as options for the permanent mounting of GM5AH and GM5AHL Series strip heaters to a countertop.

1. Determine the exact mounting location on the countertop for the unit. Refer to "Installation Site Requirements" in the INSTALLATION section of this manual.
2. Prepare the location of each stand mounting flange on the mounting surface. It is recommended to use the included template for best results.
 - a. Lay the included template on the countertop in the mounting location for mounting hole and conduit hole locations. Use the "Stand Mounting Measurements" table and the illustration for mounting dimensions, if the template is not available.
 - b. Verify which stand will have the conduit and LED wire leads passing through it and the mounting surface.
 - c. If necessary, remove the backing from the template and carefully lay the template onto the mounting surface at its appropriate position.
 - d. Drill holes through the appropriate locations on the template based on the unit size.
 - e. Remove the template from the countertop, if necessary.
3. Assemble the post bracket to the top of the post using the supplied screws.

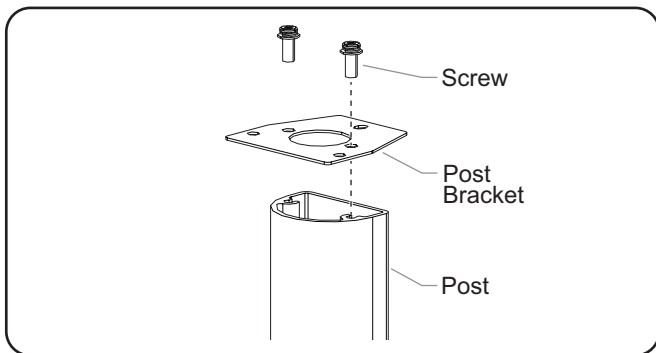

Assembling the Post

4. Feed the conduit and LED wire leads from the unit through the post.
5. Install the post to the strip heater using the supplied screws.

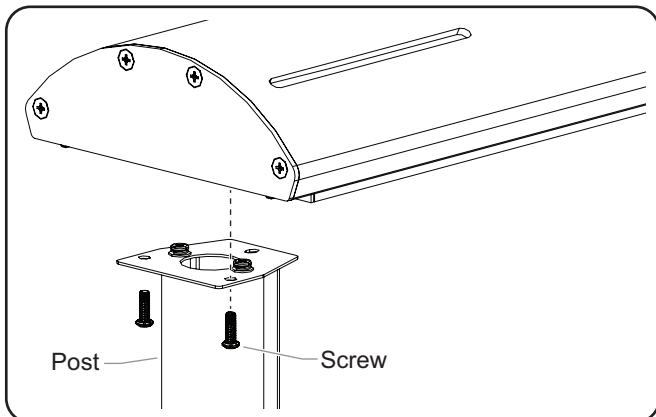

Installing the Post

6. Feed the conduit and LED wire leads from the unit through the conduit hole, and position the unit on the countertop.
7. Fasten the stands to the countertop using appropriate fasteners (not supplied by Hatco). Each mounting flange has two mounting hole locations.
8. Route the element wire leads and LED wire leads toward the installation location for the control box. Refer to the INSTALLATION section of this manual for control box/control installation.

NOTE: Mounting hole size will be determined by fastener size.

Stand Mounting Measurements

Model	Outside Flange (A)	Inside Flange (B)	Mounting Holes (C)
GM5AH-24 GM5AHL-24	594 mm (23-3/8")	511 mm (20-1/8")	538 mm (21-3/16")
GM5AH-30 GM5AHL-30	746 mm (29-3/8")	664 mm (26-1/8")	690 mm (27-3/16")
GM5AH-36 GM5AHL-36	899 mm (35-3/8")	816 mm (32-1/8")	843 mm (33-3/16")
GM5AH-42 GM5AHL-42	1051 mm (41-3/8")	969 mm (38-1/8")	995 mm (39-3/16")
GM5AH-48 GM5AHL-48	1204 mm (47-3/8")	1121 mm (44-1/8")	1148 mm (45-3/16")
GM5AH-54 GM5AHL-54	1356 mm (53-3/8")	1273 mm (50-1/8")	1300 mm (51-3/16")
GM5AH-60 GM5AHL-60	1508 mm (59-3/8")	1426 mm (56-1/8")	1453 mm (57-3/16")
GM5AH-66 GM5AHL-66	1661 mm (65-3/8")	1578 mm (62-1/8")	1605 mm (63-3/16")
GM5AH-72 GM5AHL-72	1813 mm (71-3/8")	1730 mm (68-1/8")	1757 mm (69-3/16")
GM5AH-78 GM5AHL-78	1966 mm (77-3/8")	1883 mm (74-1/8")	1910 mm (75-3/16")

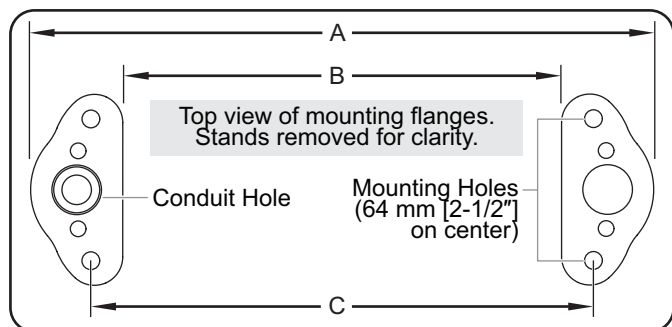

Sneeze Guard Brackets

Use the following procedure to install sneeze guard brackets on the strip heater.

NOTE: The sneeze guard is not included with the sneeze guard brackets accessory.

1. At one end of the unit, insert two mounting hooks into the end slots in the unit housing.
2. Place a mounting bracket on top of the mounting hooks with the screw holes lined up.
3. Secure the mounting bracket near the end of the unit using the supplied screws.
4. Screw the standoff to the top of the mounting bracket.

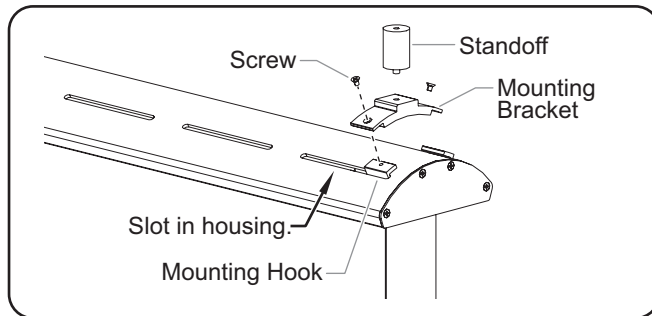

Securing the Mounting Bracket

5. Install the other mounting bracket assembly onto the opposite end of the unit.
6. Verify the the brackets are installed at the distance necessary to line up with the sneeze guard holes.

7. Place one washer on top of each standoff.
8. Place the sneeze guard (not supplied) on top of the standoffs, aligning the holes.
9. Place one washer on each hole on top of the sneeze guard.
10. Secure the sneeze guard to the unit using the thumbscrews.

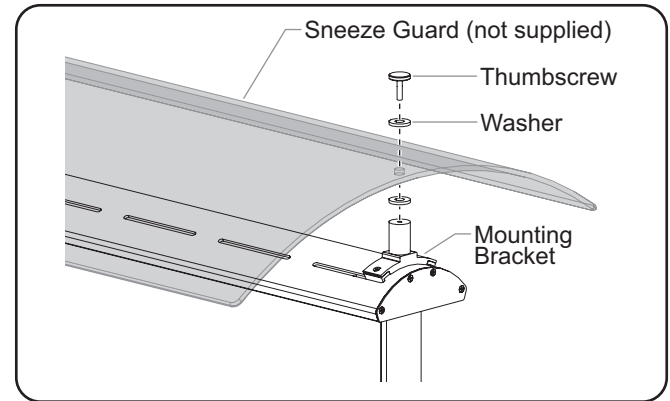

Securing a Sneeze Guard

SERVICE INFORMATION

The warranty on this Hatco unit is for one year from date of purchase or eighteen months from date of shipping from Hatco, whichever occurs first.

If you experience a problem with this unit during the warranty period, please do the following:

Contact Local Hatco Dealer

When contacting the Hatco dealer for service assistance, please supply the dealer with the following information to ensure prompt processing:

- Model of unit
- Serial number (located on unit)
- Specific problem with the unit
- Date of purchase
- Name of business
- Shipping address
- Contact name and phone number

The Hatco dealer will do the following:

- Provide replacement part(s) as required
- Submit warranty claim to Hatco for processing

Non-Warranty Problems

If you experience a non-warranty problem that requires assistance, please contact the nearest Authorized Hatco Service Agency.

To locate the nearest Service Agency:

- call Hatco at (0512) 6732-5091
- e-mail Hatco at infocn@hatcocorp.com

WARRANTY, EXCLUSIVE REMEDY:

Hatco Corporation (Seller) warrants that the products it manufactures (Products) will be free from defects in materials and workmanship under normal use and service and when stored, maintained, and installed in strict accordance with factory recommendations. Seller's sole obligation to the person or entity buying the Products directly from Seller (Customer) under this warranty is the repair or replacement by Seller or a Seller-authorized service agency, at Seller's option, of any Product or any part thereof deemed defective upon Seller's examination, for a period of: (i) the Warranty Duration from the date of shipment by Seller or (ii) the Warranty Duration from the date of Product registration in accordance with Seller's written instructions, whichever is later. The "Warranty Duration" shall mean a period of eighteen months (18) months, or the periods set forth below for specific Product components. Credit for Products or parts returned with the prior written permission of Seller will be subject to the terms shown on Seller's material return authorization form. PRODUCTS OR PARTS RETURNED WITHOUT PRIOR WRITTEN PERMISSION OF SELLER WILL NOT BE ACCEPTED FOR CREDIT. Expenses incurred by Customer in returning, replacing or removing the Products will not be reimbursed by Seller. If the defect comes under the terms of the limited warranty, the Products will be repaired or replaced and returned to the Customer and the cost of return freight will be paid by Seller. The remedy of repair or replacement provided for herein is Customer's exclusive remedy. Any improper use, alteration, repairs, tampering, misapplication, improper installation, application of improper voltage, or any other action or inaction by Customer or others (including the use of any unauthorized service agency) that in Seller's sole judgment adversely affects the Product shall void this warranty. The warranty expressly provided herein may only be asserted by Customer and may not be asserted by Customer's customers or other users of the Products; provided, however, that if Customer is an authorized equipment dealer of Seller, Customer may assign the warranty herein to Customer's customers, subject to all of the limitations of these Terms, and in such case, the warranty shall be exclusively controlled by Seller in accordance with these Terms. THIS LIMITED WARRANTY IS EXCLUSIVE AND IS IN LIEU OF ANY OTHER WARRANTY, EXPRESSED OR IMPLIED, INCLUDING BUT NOT LIMITED TO ANY IMPLIED WARRANTY OF NONINFRINGEMENT, MERCHANTABILITY, OR FITNESS FOR A PARTICULAR PURPOSE, WHICH ARE EXPRESSLY DISCLAIMED.

Two (2) Year Parts Warranty:

- Conveyor Toaster Elements (metal sheathed)
- Drawer Warmer Elements (metal sheathed)
- Drawer Warmer Drawer Rollers and Slides
- Food Warmer Elements (metal sheathed)
- Display Warmer Elements (metal sheathed air heating)
- Holding Cabinet Elements (metal sheathed air heating)
- Heated Well Elements — HW, HWB, and HWBI Series (metal sheathed)
- Induction Ranges
- Induction Warmers

Five (5) Year Parts Warranty:

- 3CS and FR Tanks

Ten (10) Year Parts Warranty:

- Electric Booster Heater Tanks
- Gas Booster Heater Tanks

Ninety (90) Day Parts-Only Warranty:

- Replacement Parts

Notwithstanding anything herein to the contrary, the limited warranty herein will not cover components in Seller's sole discretion such as, but not limited to, the following: coated incandescent light bulbs, fluorescent lights, heat lamp bulbs, coated halogen light bulbs, halogen heat lamp bulbs, xenon light bulbs, LED light tubes, glass components, and fuses; Product failure in booster tank, fin tube heat exchanger, or other water heating equipment caused by liming, sediment buildup, chemical attack, or freezing.

WARRANTY REGISTRATION INSTRUCTIONS:

Product registration must be submitted within 90 days from the date of shipment from our factory to qualify for additional coverage. Registration may be submitted through the form on Seller's website, through the form accessible through the QR code on the Product (where available), or by calling Customer Service with the required information at: **+1-414-671-6350**.

LIMITATION OF LIABILITY:

SELLER WILL NOT BE LIABLE FOR ANY INDIRECT, INCIDENTAL, CONSEQUENTIAL, PUNITIVE, EXEMPLARY, OR SPECIAL DAMAGES, INCLUDING WITHOUT LIMITATION ANY LOST PROFITS, COSTS OF SUBSTITUTE PRODUCTS, OR LABOR COSTS ARISING FROM THE SALE, USE, OR INSTALLATION OF THE PRODUCTS, FROM THE PRODUCTS BEING INCORPORATED INTO OR BECOMING A COMPONENT OF ANOTHER PRODUCT, OR FROM ANY OTHER CAUSE WHATSOEVER, WHETHER BASED ON WARRANTY (EXPRESSED OR IMPLIED) OR OTHERWISE BASED ON CONTRACT, TORT, OR ANY OTHER THEORY OF LIABILITY, AND REGARDLESS OF ANY ADVICE OR REPRESENTATIONS THAT MAY HAVE BEEN RENDERED BY SELLER CONCERNING THE SALE, USE, OR INSTALLATION OF THE PRODUCTS, EVEN IF SELLER IS AWARE OF THE POSSIBILITY OF SUCH DAMAGES. IN NO EVENT WILL SELLER'S AGGREGATE LIABILITY ARISING OUT OF OR RELATED TO THIS AGREEMENT EXCEED THE TOTAL AMOUNTS PAID TO SELLER BY CUSTOMER FOR THE PRODUCTS WITHIN THE THREE (3) MONTH PERIOD IMMEDIATELY PRECEDING THE EVENT GIVING RISE TO CUSTOMER'S CLAIM. THE LIMITATIONS SET FORTH HEREIN REGARDING SELLER'S LIABILITY SHALL BE VALID AND ENFORCEABLE NOTWITHSTANDING A FAILURE OF ESSENTIAL PURPOSE OF THE LIMITED REMEDY SPECIFIED IN THESE TERMS.

Seller reserves the right to update these Terms at any time, at its sole discretion, which become binding upon the date of publishing. For the most current version of our full Terms of Sale, see our website at: <https://www.hatcocorp.com/terms-of-sale>

使用者重要注意事项	15
简介	15
重要安全说明	16
型号说明	17
型号命名	17
规格	17
插头型式	17
电气参数表	18
尺寸 — 长条形保温灯	19
尺寸 — 控制盒	19
安装	19
总则	19
安装位置要求	20
安装设备	20
安装垂直表面安装的控制盒	21
安装架子下面安装的控制盒	22

操作	23
总则	23
维护保养	23
总则	23
每日清洁	23
更换陈列柜灯	23
故障处理指南	24
选配及配件	25
全球有限质保	27
服务事项	27

使用者重要注意事项

请在下面空白处记录产品型号、序列号（规格标签位于设备底面）、电压和购买日期。当致电赫高寻求服务时，请提供这些信息。

型号 _____

序列号 _____

电压 _____

购买日期 _____

工作时间： 北京时间 上午 9:00 – 下午 6:00

电话： (0512) 6732-5091

E-mail: infocn@hatcocorp.com

查询更多信息请访问我们的网站：www.hatcocorp.com
www.hatcocorp.cn

简介

Hatco GLOMAX® 弧形长条形保温灯使热食品保持在最佳就餐温度更长时间。时尚的弯曲设计可最大限度降低长条形保温灯的尺寸，同时照射和加热下方的食品。专门设计的反射器可反射来自元件的热量，从而安全地将最高就餐温度维持更长时间，因此在烹饪食物时无需超过最佳食用温度。GLOMAX 弧形长条形保温灯非常适于前厅应用，例如自助餐和供应线路。

GLOMAX 弧形长条形保温灯是经过广泛研究和现场测试的产品。所用材料经久耐用，外型美观，性能优异。在装运前每个组件都进行了全面检测。

本手册包含 GLOMAX 弧形长条形保温灯的安装、安全和操作说明。建议在安装和操作该设备前仔细阅读该手册。

本手册中的安全信息采用以下标志表示：



“警告”表示有危险情况，如果不加以避免，则可能导致人身伤亡。



“小心”表示有危险情况，如果不加以避免，则可能导致轻度或中度人身伤害。



“注意”用于提示不会涉及人身伤害的操作。

注意：请参阅本手册封底上的符号标识表，了解本手册中可能出现的符号的定义。

⚠ 使用本设备前，请仔细阅读下列重要安全事项，以免造成严重的人身伤亡及设备或财产的损坏。

⚠ 警告

触电危险：

- 将设备插入电压、尺寸及插头配置均正确且妥当接地的电气插座中。如果插头和插座不匹配，请联系合格的技术人员确定并安装正确电压和尺寸的电气插座。
- 垂直表面安装的控制盒必须安装在垂直表面上。控制盒安装到水平表面可能导致液体聚积，进而导致触电。
- 在进行任何清洁、调整或维护之前，请先关闭电源开关，拔下电源线/关掉断路器电源，并使设备冷却。
- 请勿将设备浸入水中或浸湿。本设备不防水。严禁使用被水浸过或浸湿的设备。
- 本设备不具备“防喷淋”结构。请勿使用喷淋头清洁本设备。
- 请勿用蒸汽或使用过多的水清洁设备。
- 如果电源软线损坏，为了避免危险，必须由制造商、其维修部门或类似部门的专业人员更换。
- 维修时只能使用正宗的 Hatco 更换零部件。未使用正宗 Hatco 更换零部件会造成质保无效，并可能造成设备操作人员受到有害电压威胁，并引起触电或着火。正宗 Hatco 更换零部件可以保证使用环境下的安全生产。某些普通零部件不具备相关特性，从而无法在 Hatco 设备内安全使用。

火警：

- 不要将设备安装在可燃表面上方或附近。否则可能会导致变色或着火。设备仅能安装在不可燃周围环境中。
- 不要将长条形保温灯安装在不可燃表面上方不足 254 mm (10") 的位置。如果不保持安全距离，可能会导致褪色或燃烧。

爆炸危险：在该设备或其他任何装置附近，请勿储存或使用汽油或其他可燃蒸汽或液体。

确保所有操作人员都已了解如何安全和妥善地使用本设备。

对于身体、感官或智力上有缺陷，或经验和知识有欠缺的人（包括儿童），此说明书不适用。

⚠ 警告

仅使用 Hatco 批准的专为食品存放区域设计的 LED 灯组件。使用并非设计用于食品存放区域的 LED 灯组件可能导致人身伤害和/或食品污染。

确保食品在放入设备前已被加热至适当的食品安全温度。未能正确加热食品可能会导致严重的健康风险。本设备仅限存放预热食品。

本设备不含“用户维修”零部件。如需维修，请联系赫高授权服务机构或赫高服务部门，电话 (0512) 6732-5091。

⚠ 小心

燃烧危险：本设备的某些外表面处温度较高。接触这些部位时请务必小心。

首次启动设备，标准及经批准的制造用油可能会导致设备冒烟，长达 30 分钟。这只是暂时状态。在不放入食品的情况下继续运行设备，直至烟雾消散。

若要确保安全和正确运行，请参阅本手册“安装”部分中的“安装位置要求”。

注意

设备需要使用特定电压。在开始安装之前，请参考规范标签的供电需求。

不要添加装饰性底面，试图隐藏安装递菜口的长条形保温灯。过热会导致设备故障。

在温度高于 40°C (104°F) 的区域外安装壁挂遥控控制盒。过高的温度将导致控制器过热、故障和失效。

因为 Hatco 设备产生热量造成的任何台面材料损伤，都不在 Hatco 的保修范围内。请联系台面材料厂家，获取应用信息。

只允许使用非摩擦性清洁剂。摩擦性清洁剂可能会刮伤本设备的表面处理层，破坏其外观，并易使表面积尘。

请勿将设备置于气流过急的环境中。避免将设备置于空气流动或气流活跃的区域（即排气扇/排风罩、空调管和外门附近）。

所有型号

所有 GLOMAX® 弧形长条形保温灯由适于在窄小空间安装的弯曲铝外壳组成。预聚焦的加热范围让管状元件的热量覆盖到下方整个存放表面。弧形长条形保温灯有 610–1982 mm (24"–78") 的宽度可供选择。表面处理选择包括本色阳极氧化和黑色阳极氧化。

弯曲红外线长条形保温灯配备用于在架子下面安装的角形托架并随附 1.5 m (5') 电源线和插头。

注意：请参阅“选件及附件”部分了解工作台面安装选项和安装。

GM5AH 型号

这些型号仅能加热。控制器位于壁挂遥控控制盒中并包含无限加热控制钮和电源指示灯。

GM5AHL 型号

除了加热外，这些型号还包含两个 LED灯条，可提供暖白光 (3050 K) 照射下方的食品。控制器位于壁挂遥控控制盒中并包含无限加热控制钮、电源指示灯和照明 I/O (打开/关闭) 开关。

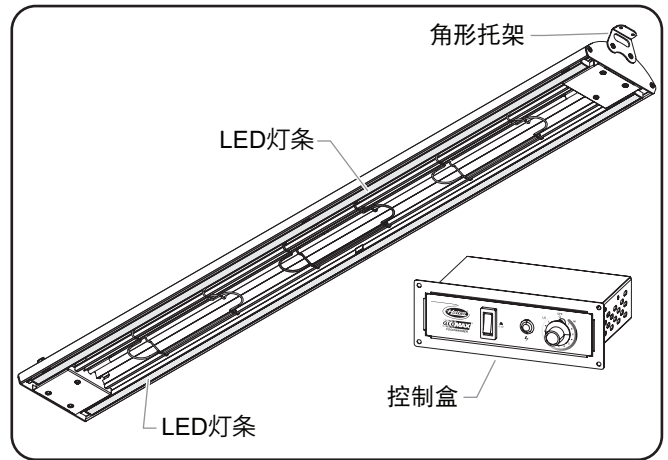

GM5AHL 系列长条形保温灯

型号命名

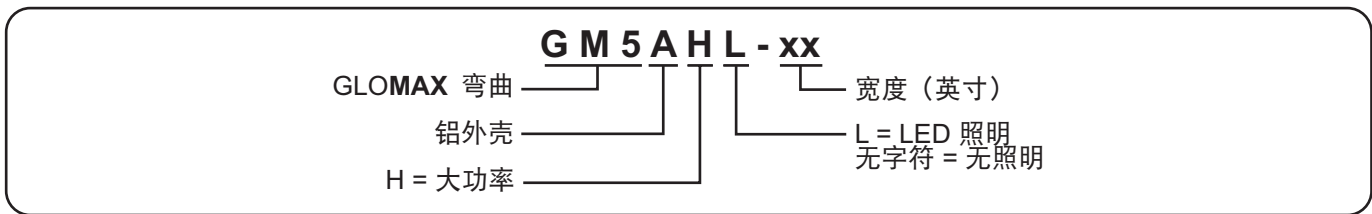

规格

插头型式

设备出厂附带一根装有插头的电线。根据应用情况，相应提供插头。



触电危险：将设备插头妥善插入有接地的电气插座内，插入前请核对电压、规格和插头型式是否正确。如果插头和插座不匹配，请和有正式资格的电工联系，以确定并安装电压和规格正确的电气插座。

注意：HATCO不提供插座。

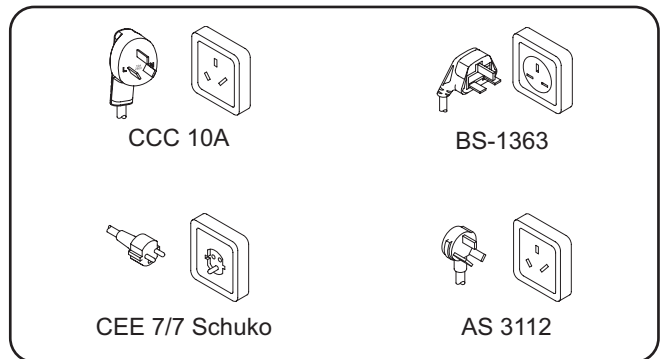

插头型式

注意：规格标签位于设备底面。查看标签上的序列号和设备电气参数信息。

电气参数表 — GM5AH 型号

型号	电压 (V)	功率 (W)	电流 (A)	插头型式	出厂重量
GM5AH-24	220-230	500-546	2.3-2.4	CCC 10A, BS-1363, CEE 7/7 Schuko, AS 3112	5 kg (10 lbs.)
	230-240	495-500	1.9-2.1		
GM5AH-30	220-230	660-721	3.0-3.1	CCC 10A, BS-1363, CEE 7/7 Schuko, AS 3112	5 kg (11 lbs.)
	230-240	606-660	2.6-2.8		
GM5AH-36	220-230	800-874	3.6-3.8	CCC 10A, BS-1363, CEE 7/7 Schuko, AS 3112	6 kg (13 lbs.)
	230-240	735-800	3.2-3.3		
GM5AH-42	220-230	950-1038	4.3-4.5	CCC 10A, BS-1363, CEE 7/7 Schuko, AS 3112	7 kg (15 lbs.)
	230-240	872-950	3.8-4.0		
GM5AH-48	220-230	1100-1202	5.0-5.2	CCC 10A, BS-1363, CEE 7/7 Schuko, AS 3112	7 kg (16 lbs.)
	230-240	1010-1100	4.4-4.6		
GM5AH-54	220-230	1250-1366	5.7-5.9	CCC 10A, BS-1363, CEE 7/7 Schuko, AS 3112	8 kg (18 lbs.)
	230-240	1148-1250	5.0-5.2		
GM5AH-60	220-230	1400-1530	6.4-6.7	CCC 10A, BS-1363, CEE 7/7 Schuko, AS 3112	8 kg (18 lbs.)
	230-240	1286-1400	5.4-5.8		
GM5AH-66	220-230	1560-1705	7.1-7.4	CCC 10A, BS-1363, CEE 7/7 Schuko, AS 3112	9 kg (19 lbs.)
	230-240	1433-1560	6.2-6.5		
GM5AH-72	220-230	1725-1885	7.8-8.2	CCC 10A, BS-1363, CEE 7/7 Schuko, AS 3112	10 kg (21 lbs.)
	230-240	1584-1725	6.6-7.2		
GM5AH-78	220-230	1890-2066	8.6-9.0	CCC 10A, BS-1363, CEE 7/7 Schuko, AS 3112	11 kg (24 lbs.)
	230-240	1736-1890	7.5-7.9		

电气参数表 — GM5AHL 型号

型号	电压 (V)	功率 (W)	电流 (A)	插头型式	出厂重量
GM5AHL-24	220-230	510-555	2.3-2.4	CCC 10A, BS-1363, CEE 7/7 Schuko, AS 3112	5 kg (12 lbs.)
	230-240	467-510	2.0-2.1		
GM5AHL-30	220-230	670-733	3.0-3.2	CCC 10A, BS-1363, CEE 7/7 Schuko, AS 3112	6 kg (13 lbs.)
	230-240	616-670	2.7-2.8		
GM5AHL-36	220-230	812-888	3.7-3.9	CCC 10A, BS-1363, CEE 7/7 Schuko, AS 3112	7 kg (15 lbs.)
	230-240	748-812	3.2-3.4		
GM5AHL-42	220-230	964-1053	4.4-4.6	CCC 10A, BS-1363, CEE 7/7 Schuko, AS 3112	7 kg (15 lbs.)
	230-240	885-964	3.8-4.0		
GM5AHL-48	220-230	1116-1220	5.1-5.3	CCC 10A, BS-1363, CEE 7/7 Schuko, AS 3112	8 kg (17 lbs.)
	230-240	1025-1116	4.5-4.7		
GM5AHL-54	220-230	1267-1384	5.8-6.0	CCC 10A, BS-1363, CEE 7/7 Schuko, AS 3112	9 kg (19 lbs.)
	230-240	1163-1267	5.1-5.3		
GM5AHL-60	220-230	1418-1550	6.4-6.7	CCC 10A, BS-1363, CEE 7/7 Schuko, AS 3112	9 kg (20 lbs.)
	230-240	1302-1418	5.7-5.9		
GM5AHL-66	220-230	1579-1726	7.2-7.5	CCC 10A, BS-1363, CEE 7/7 Schuko, AS 3112	10 kg (21 lbs.)
	230-240	1450-1579	6.3-6.6		
GM5AHL-72	220-230	1744-1907	7.9-8.3	CCC 10A, BS-1363, CEE 7/7 Schuko, AS 3112	10 kg (22 lbs.)
	230-240	1602-1744	7.0-7.3		
GM5AHL-78	220-230	1910-2088	8.7-9.1	CCC 10A, BS-1363, CEE 7/7 Schuko, AS 3112	11 kg (24 lbs.)
	230-240	1754-1910	7.6-8.0		

尺寸 — 长条形保温灯

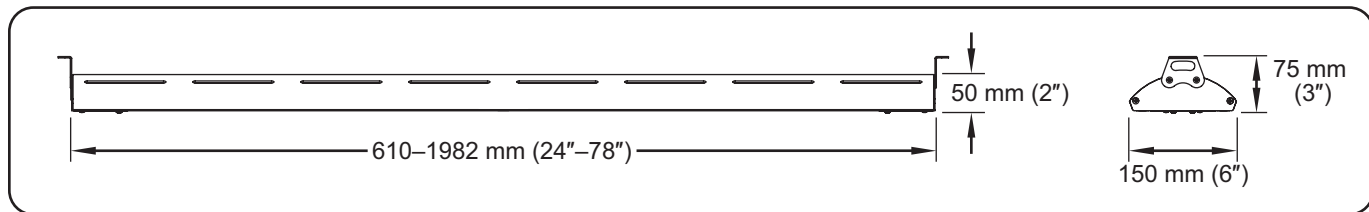

尺寸 — 控制盒

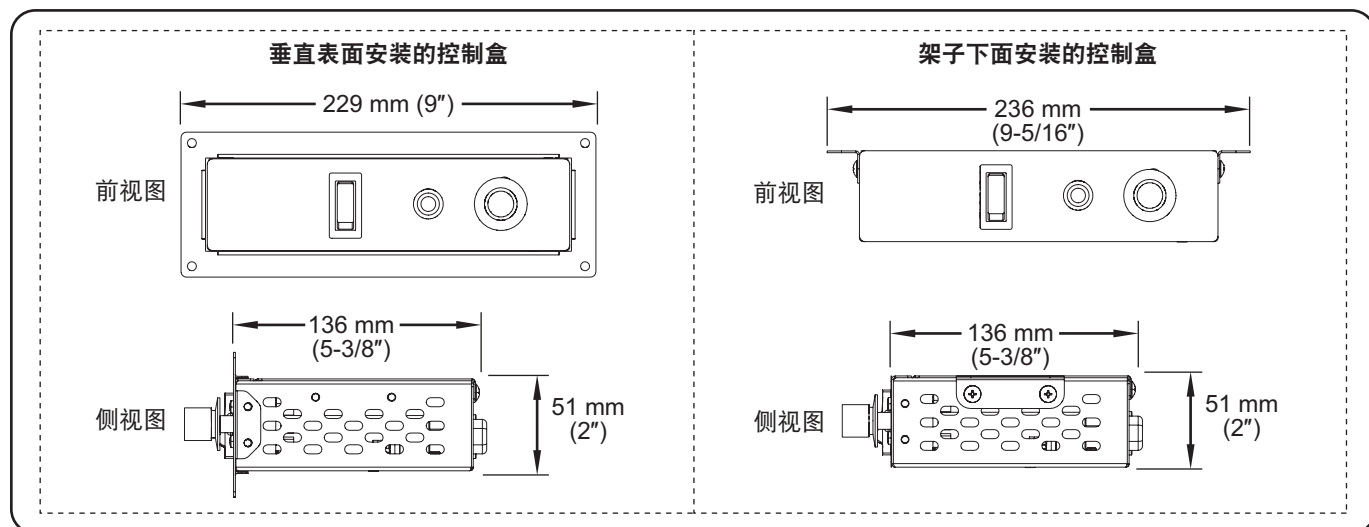

安装

总则

使用本部分中的信息安装 GLOMAX® 弧形长条形保温灯。长条形保温灯发货时尽可能进行了组件预安装。

警告

触电危险：将设备插入电压、尺寸及插头配置均正确且妥当接地的电气插座中。如果插头和插座不匹配，请联系合格的技术人员确定并安装正确电压和尺寸的电气插座。

火警：

- 不要将设备安装在可燃表面上方或附近。否则可能会导致变色或着火。设备仅能安装在不可燃周围环境中。
- 不要将长条形保温灯安装在不可燃表面上方不足 254 mm (10") 的位置。如果不保持安全距离，可能会导致褪色或燃烧。

小心

若要确保安全和正确运行，请参阅本手册“安装”部分中的“安装位置要求”。

注意

设备需要使用特定电压。在开始安装之前，请参考规范标签的供电需求。

不要添加装饰性底面，试图隐藏安装递菜口的长条形保温灯。过热会导致设备故障。

因为 Hatco 设备产生热量造成的任何台面材料损伤，都不在 Hatco 的保修范围内。请联系台面材料厂家，获取应用信息。

注意：在安装设备之前，请联系台面基材生产商，获取应用信息和表面温度限制。

1. 从发货箱取出设备和控制盒，并取下所有包装材料。

注意：为防止延迟获得保修，请完成在线保修登记。有关详细信息，请参见“重要用户信息”部分。

2. 去除设备表面的胶带保护性包装。

注意：对于配备管状支架的设备，请参阅“选件及附件”部分了解安装详细信息。

- 将设备安装到适当位置。请参阅本部分中的“安装位置要求”和“安装设备”程序。
 - 将设备置于环境气温恒定的地方，最低温度为 21°C (70°F)。避免将设备置于空气流动或气流活跃的区域（即排气扇/排风罩、空调管和外门附近）。
 - 验证是否符合最低间隙要求和建议安装高度。请参阅本部分中的“安装位置要求”。
 - 长条形保温灯可以安装到蒸汽柜上方。遵循标准最低间隙要求。
- 将遥控盒安装到所需位置。请参阅此部分中的“安装垂直表面安装的控制盒”或“安装架子下面安装的控制盒”了解详细信息。

安装位置要求

安装位置必须满足安全和正确安装设备的具体要求。

- 确保工作台面材料设计为能长期承受热食品存放温度。请联系台面材料厂家，获取应用信息。
- 确保安装位置与相邻表面具有正确的最低间隙。



警告

火灾危险： 不要将设备安装在可燃表面上方或附近。否则可能会导致变色或着火。设备仅能安装在不可燃周围环境中。

最低间隙要求—不可燃周围环境

型号	A	B	C
GM5AH 和 GM5AHL	254 mm (10")	0 mm (0")	25 mm (1")

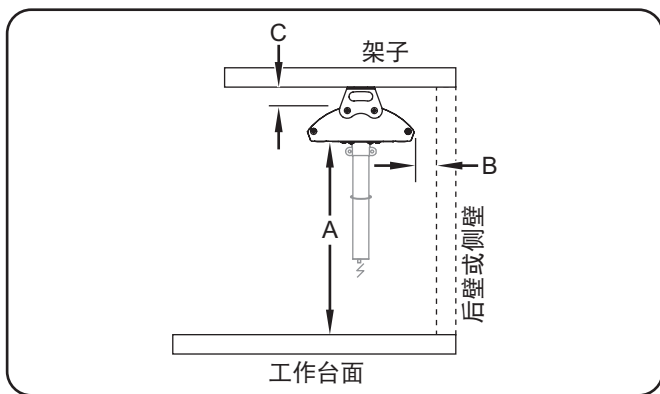

最低间隙

注意：长条形保温灯可以安装到蒸汽柜上方。遵循最低间隙要求。

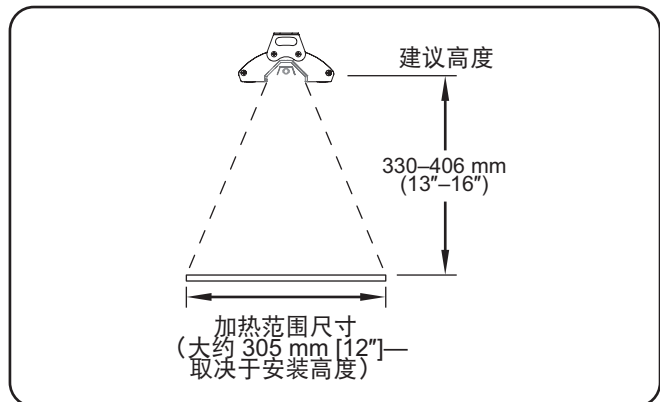

注意：加热范围尺寸取决于设备高度。

安装设备

使用下列程序，利用随附的角形托架安装设备。

注意：设备随附 1.5 m (5') 电源线和插头。

注意

因为 Hatco 设备产生热量造成的任何台面材料损伤，都不在 Hatco 的保修范围内。请联系台面材料厂家，获取应用信息。

- 使用随附的螺丝将角形支架安装到设备上。

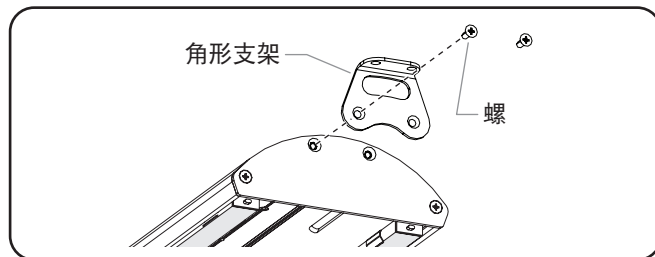

角度支架安装

- 确定在架子底面上的准确安装位置。

注意：随附的角形托架在设备和顶部架子之间提供 25 mm (1") 的间隙。

注意：设备可以安装一个平面架子或有卷边/法兰边缘的架子上。安装设备时，其距顶部架子最低部分的间隙至少应为 25 mm (1")。例如，如果架子具有 25 mm (1") 的法兰边缘，则需要将设备安装到距架子下方距底面 51 mm (2") 的位置。如果不能保证最小间距，可能会损毁周围环境和/或导致设备故障。

- 使用适当紧固件（Hatco 不提供）将角形支架紧固到架子的底面。在将设备紧固到架子上之前，确保设备朝向所需方向，导线位于正确一侧。

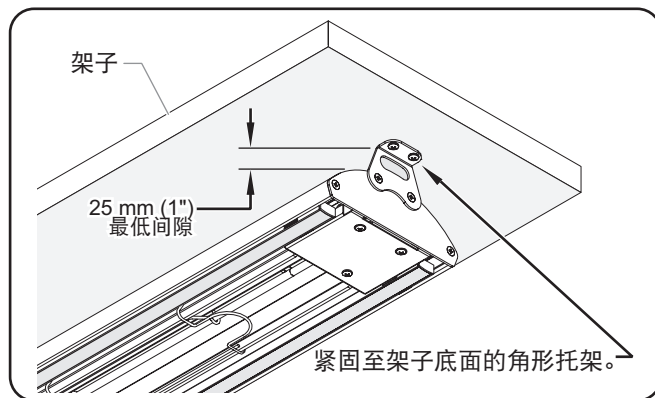

平面架子安装

- 将元件导线和 LED 导线拉到控制盒的安装位置。

安装垂直表面安装的控制盒

请使用以下程序安装垂直表面安装的控制盒。

警告

垂直表面安装的控制盒必须安装在垂直表面上。控制盒安装到水平表面可能导致液体聚积，进而导致触电。

注意

在温度高于 104°F (40°C) 的区域外安装壁挂遥控控制盒。过高的温度将导致控制器过热、故障和失效。

重要提示：

壁挂遥控控制盒和控制开关必须安装在凉爽、干燥且距任何加热区域尽可能远的位置。不要将控制盒直接安装在设备上或者设备的下方或上方。不要将控制盒安装在与任何受热表面直接接触的位置或产生蒸汽的设备附近。

1. 在即将安装控制盒的垂直表面切割并钻适当孔。请参阅“控制盒开口和螺丝孔尺寸”图示了解开口和螺丝孔尺寸。

注意：确保控制盒安装位置在垂直表面后提供足够空间，以容纳控制盒的深度和电气连接。

2. 通过开孔将元件导线和 LED 导线从设备拉到控制盒，然后进行电气连接。
3. 将电源线插入电压、尺寸及插头配置均正确且妥当接地的电气插座中。有关详细信息，请参阅“规格”部分。

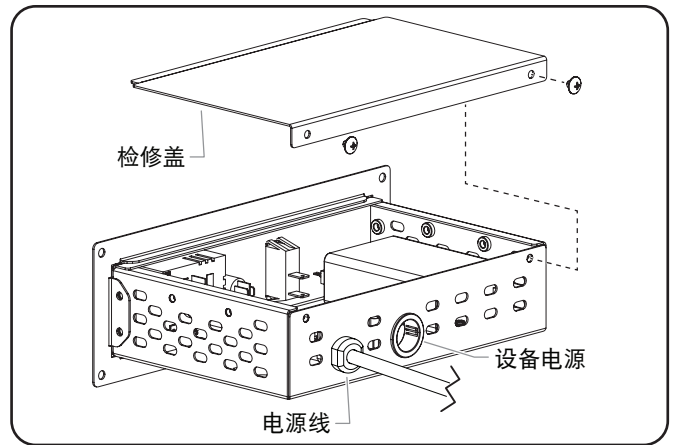

垂直表面安装的控制盒电气连接

4. 将控制盒从前面放到开口中。确保电线未被夹住或压住。
5. 在控制盒凸缘接触柜面的位置，涂上 6 mm (1/4") 宽 NSF 批准的硅密封胶。
6. 使用四根螺丝（未提供），将控制盒紧固在垂直表面上。

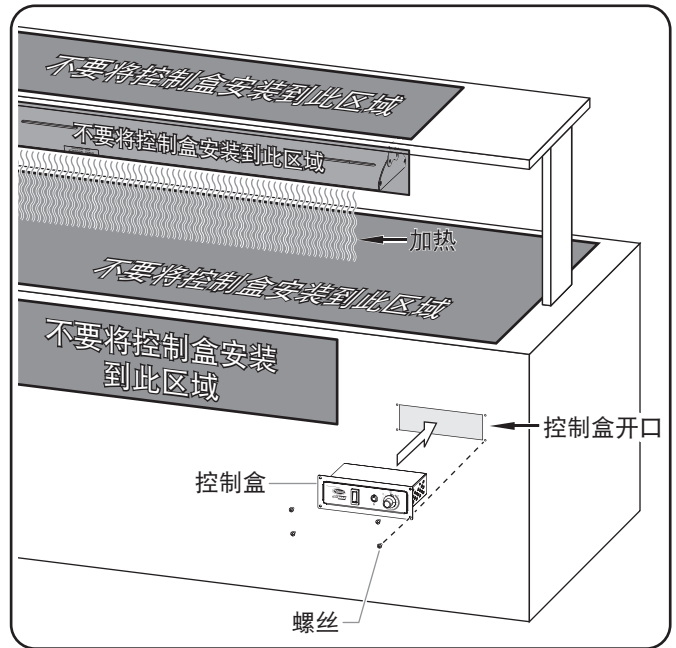

安装垂直表面安装的控制盒

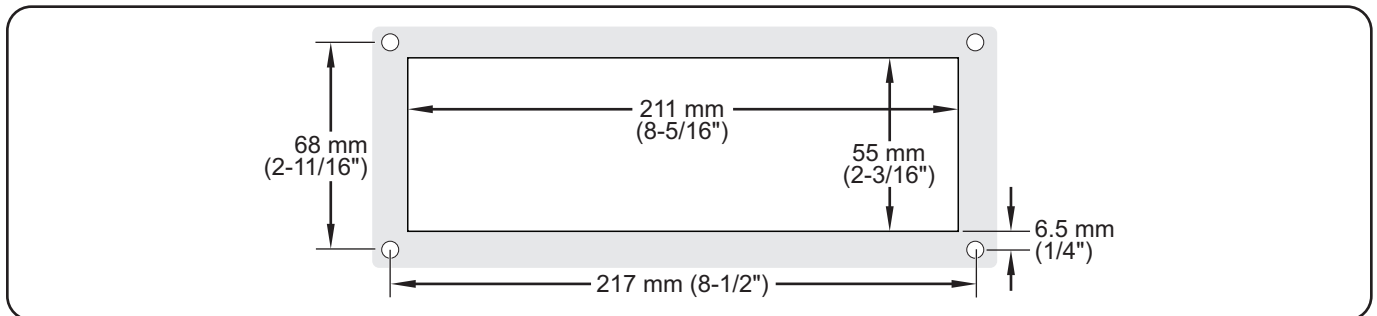

控制盒开口和螺丝孔尺寸

安装架子下面安装的控制盒

请遵照以下程序安装架子下面安装的控制盒。

注意

在温度高于 104°F (40°C) 的区域外安装壁挂遥控控制盒。过高的温度将导致控制器过热、故障和失效。

重要提示:

壁挂遥控控制盒和控制开关必须安装在凉爽、干燥且距任何加热区域尽可能远的位置。不要将控制盒直接安装在设备上或者设备的下方或上方。不要将控制盒安装在与任何受热表面直接接触的位置或产生蒸汽的设备附近。

1. 如有必要，在即将安装控制盒的表面钻适当的孔。请参阅“控制盒螺丝孔尺寸”图示了解螺丝孔尺寸。

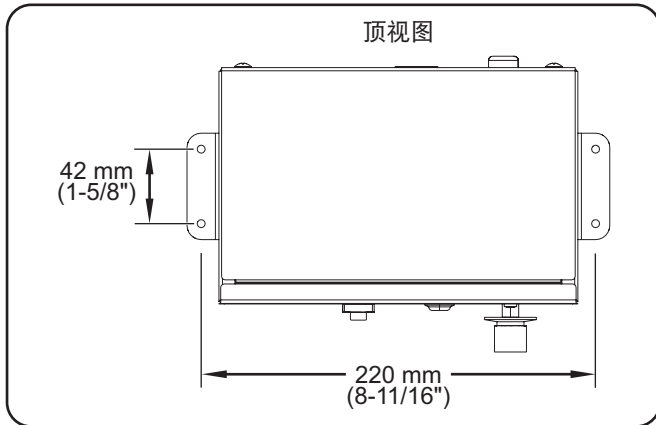

控制盒螺丝孔尺寸

注意：确保控制盒安装位置提供足够空间，以容纳控制盒的深度和电气连接。

2. 将元件导线和 LED 导线从设备拉到控制盒，然后进行电气连接。
3. 将电源线插入电压、尺寸及插头配置均正确且妥当接地的电气插座中。有关详细信息，请参阅“规格”部分。

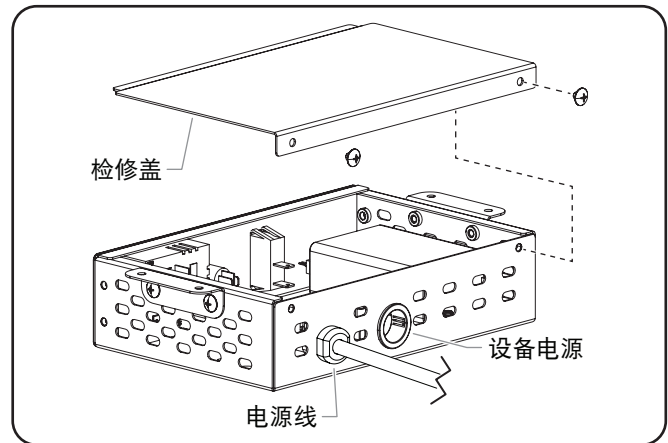

架子下面安装的控制盒电气连接

4. 将控制盒放入水平表面下方的位置中。确保电线未被夹住或压住。
5. 使用四根螺丝（未提供），将控制盒紧固在垂直表面上。

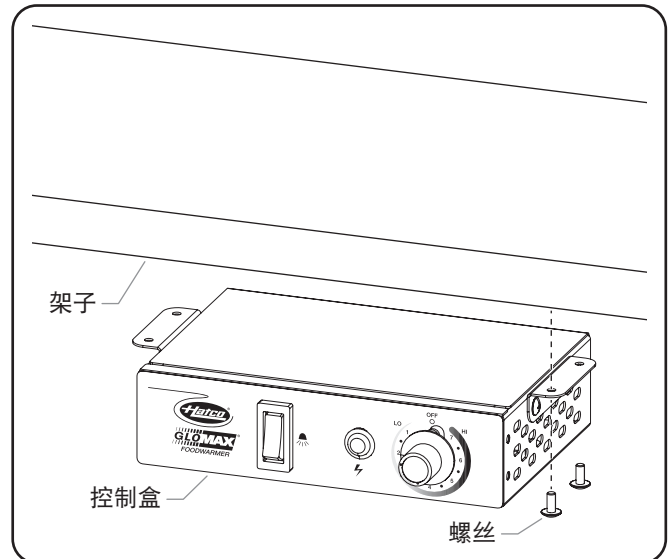

安装架子下面安装的控制盒

总则

GLOMAX® 弧形长条形保温灯的设计便于操作。请按照以下信息和程序来操作。

警告

操作本设备前，请仔细阅读“重要安全事项”中的所有安全说明。

小心

烫伤危险：本设备的某些外表面处温度较高。接触这些部位时请务必小心。

首次启动设备，标准及经批准的制造用油可能会导致设备冒烟，长达 30 分钟。这只是暂时状态。在不放入食品的情况下继续运行设备，直至烟雾消散。

控制

GM5AH 和 GM5AHL 系列弧形长条形保温灯包含一个壁挂遥控控制盒。下面是控制盒内控制器的列表。

无限加热控制钮—打开和关闭加热元件的电源，并控制元件的热输出。

照明 I/O (打开/关闭) 翘板开关—打开和关闭 LED 光带的电源（若配备）。

电源指示灯—电源接通时亮起，电源断开时熄灭。

启动

1. 打开长条形保温灯。
 - 将无限加热控制钮转至所需的设置。
 - 指示灯将亮起，加热元件将通电。
2. 将照明 I/O (打开/关闭) 开关移至 I (打开) 位置（若配备）。
 - LED 光带亮起（若配备）。
3. 将预热食品放到长条形保温灯下之前，等待 30 分钟让设备达到工作温度。

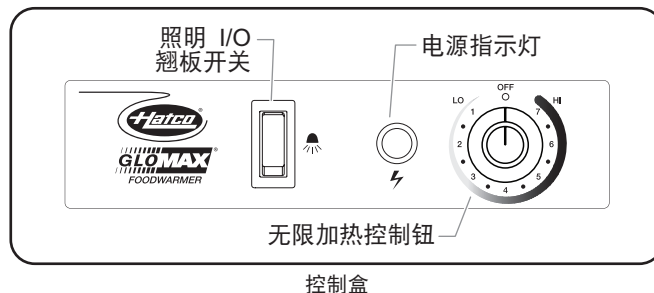

关机

1. 将无限加热控制钮转至 O (关闭) 位置。
 - 指示灯将熄灭，加热元件将关闭。
2. 将照明 I/O (打开/关闭) 开关移至 O (关闭) 位置（若配备）。LED 灯将熄灭（若配备）。

维护保养

总则

GLOMAX 弧形长条形保温灯的设计经久耐用、性能优异且易于维护。

警告

触电危险：

- 在进行任何清洁、调整或维护之前，请先关闭电源开关，拔下电源线/关掉断路器电源，并使设备冷却。
- 请勿将设备浸入水中或浸湿。本设备不防水。严禁使用被水浸过或浸湿的设备。
- 本设备不具备防喷淋结构。请勿使用喷淋头清洁本设备。
- 请勿用蒸汽或使用过多的水清洁设备。
- 维修时只能使用正品 Hatco 更换零部件。未使用正品 Hatco 更换零部件会导致质保失效，使设备操作人员受到有害电压威胁，并引起触电或着火。正品 Hatco 更换零部件可以保证使用环境下的安全运行。某些散件或通用更换零部件没有可在 Hatco 设备中安全工作的特性。

本设备不含“用户维修”零部件。如果本设备需要维修，请联系 Hatco 授权服务代理，或致电 (0512) 6732-5091 联系联系 Hatco 服务部。

仅使用 Hatco 批准的专为食品存放区域设计的 LED 灯组件。使用并非设计用于食品存放区域的 LED 灯组件可能导致人身伤害和/或食品污染。

每日清洁

为保护设备的抛光表面，建议每天清洁所有表面。

注意

只允许使用非摩擦性清洁剂。摩擦性清洁剂可能会刮伤本设备的表面处理层，破坏其外观，并易使表面积尘。

1. 关掉设备，断开电源线并让设备冷却。
2. 用非研磨的蘸水布擦拭所有金属表面。顽固污渍可使用品质良好的不锈钢或无磨料清洁剂去除。使用小刷子和温和皂清洁双手难以接触到的区域。
3. 用干净、柔软的干布擦干所有金属表面。

更换陈列柜灯—GM5AHL 系列

陈列柜灯由照亮加热区域的两个 LED 灯条组成。这些光路有特殊覆层可防止人员受伤，并能在发生破损时防止食品污染。

更换 LED 灯条必须由经过授权的 Hatco 服务代理执行。

注意：Hatco 的 LED 灯条符合食品存放和陈列区域安全标准。



本设备只能由受过培训且具备相应资格的人员负责维修。若由不具备相应资格的人员维修，则可能引起触电或着火。



触电警告：在进行任何清洁、调整或维护之前，请先关闭电源开关，拔下电源线/关掉断路器电源，并使设备冷却。

症状	可能原因	纠正措施
设备“打开”，但没有热量。	设备没有通电。	检查断路器，必要时进行重置。
	开关有缺陷。	联系授权服务代理商或赫高以获得帮助。
	线缆没有接好。	
	加热元件存在缺陷。	
加热但无灯照（仅 GM5AHL）。	LED 组件有缺陷。	联系授权服务代理商或赫高以获得帮助。
	接线错误。	
热量不够。	设备安装过高于目标区域。	降低设备的位置，使有效热量接近目标。
	长条形保温灯目标区域周围空气流动过多。	限制或重定空气流动（空调管或排气扇），使其离开设备。
	电源有误（电压低）。	检查设备电源，确保其匹配。如果电源不正确，更换电源以匹配设备。
热量过多。	设备安装过分接近目标区域。	查看安装符合类型/型号规格。如果太近，便增加安装高度。
	电源电压过高。	检查设备电源，确保其匹配。如果电源不正确，更换电源以匹配。
控制开关烧坏。	遥控控制盒的安装位置距加热区域过近。	将遥控控制盒从加热区域移走。控制盒允许的最高环境温度是 40°C (104°F)。
	并非所用开关都由 Hatco 提供。	真正的 Hatco 零件能够在使用环境中安全、正确地运行。请联系授权服务代理或 Hatco 以使用真正的 Hatco 替换零件更换开关。

对问题进行故障针对？

如果您的困境在问题解决后仍无法解除，请联系距您最近的经过授权的服务代理或 Hatco 以寻求帮助。请查找最近的服务机构，请登录 Hatco 网站 www.hatcocorp.com，选择 支持 下拉菜单，然后单击“查找服务代理”；或者联系 Hatco 零部件和服务团队：

电话： (0512) 6732-5091

电子邮件： infocn@hatcocorp.com

不可调节支架

铝制不可调节 406 mm (16") 支架作为选件提供，用于将 GM5AH 和 GM5AHL 系列长条形保温灯永久安装到工作台上。

1. 确定设备在工作台上的准确安装位置。请参阅本手册“安装”部分中的“安装位置要求”。
2. 在安装表面上准备每个支架安装法兰的位置。为取得最佳效果，建议使用附带的模板。
 - a. 将附带的模板放置在工作台上用于安装孔和导管孔的安装位置中。如果没有模板，请使用“支架安装测量值”表格和图示确定安装尺寸。
 - b. 验证哪个支架将有穿过支架和安装表面的导管和 LED 导线。
 - c. 如有必要，从模板取下垫板，并小心地将模板放置在安装表面的适当位置。
 - d. 在模板上的相应位置，根据设备尺寸钻孔。
 - e. 如有必要，从工作台面取下模板。
3. 使用随附的螺丝，将立柱托架安装到立柱顶部。

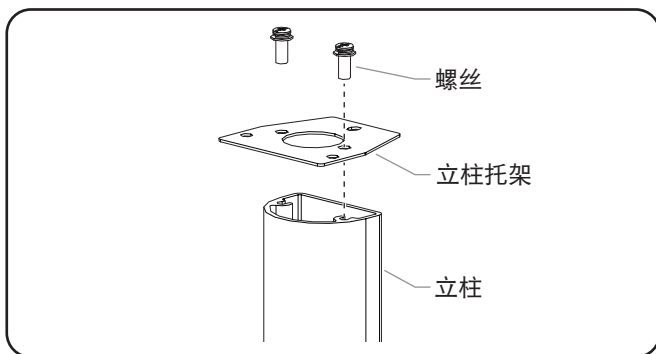

安装立柱

4. 将设备的导管和 LED 导线穿过立柱。
5. 使用随附的螺丝，将立柱安装到长条形保温灯上。

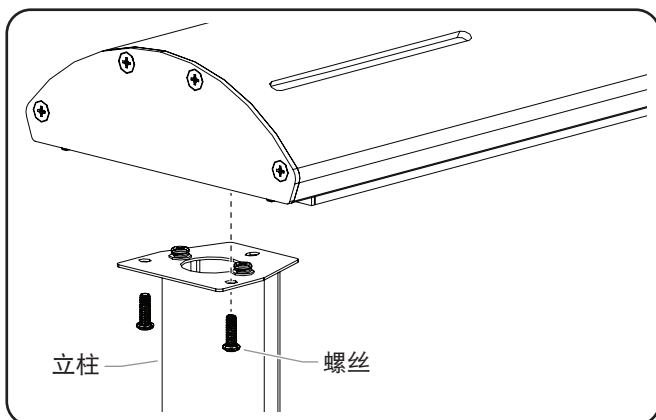

安装立柱

6. 将设备的导管和 LED 导线穿过导管孔，并将设备放置在工作台面上。
7. 使用适当紧固件（Hatco 不提供）将支架紧固到工作台上。每个安装法兰都有两个安装孔位置。
8. 将元件导线和 LED 导线拉到控制盒的安装位置。请参阅本手册的“安装”部分了解控制盒/控件器安装。

注意：安装孔尺寸取决于紧固件尺寸。

支架安装测量值

型号	外部法兰 (A)	内部法兰 (B)	安装孔 (C)
GM5AH-24 GM5AHL-24	594 mm (23-3/8")	511 mm (20-1/8")	538 mm (21-3/16")
GM5AH-30 GM5AHL-30	746 mm (29-3/8")	664 mm (26-1/8")	690 mm (27-3/16")
GM5AH-36 GM5AHL-36	899 mm (35-3/8")	816 mm (32-1/8")	843 mm (33-3/16")
GM5AH-42 GM5AHL-42	1051 mm (41-3/8")	969 mm (38-1/8")	995 mm (39-3/16")
GM5AH-48 GM5AHL-48	1204 mm (47-3/8")	1121 mm (44-1/8")	1148 mm (45-3/16")
GM5AH-54 GM5AHL-54	1356 mm (53-3/8")	1273 mm (50-1/8")	1300 mm (51-3/16")
GM5AH-60 GM5AHL-60	1508 mm (59-3/8")	1426 mm (56-1/8")	1453 mm (57-3/16")
GM5AH-66 GM5AHL-66	1661 mm (65-3/8")	1578 mm (62-1/8")	1605 mm (63-3/16")
GM5AH-72 GM5AHL-72	1813 mm (71-3/8")	1730 mm (68-1/8")	1757 mm (69-3/16")
GM5AH-78 GM5AHL-78	1966 mm (77-3/8")	1883 mm (74-1/8")	1910 mm (75-3/16")

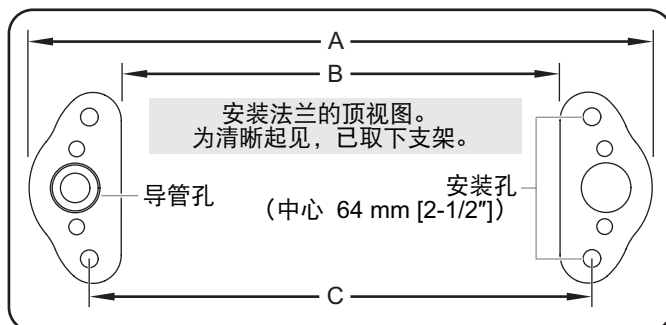

防飞沫挡板托架

遵照以下程序，在长条形保温灯上安装防飞沫挡板托架。

注意：防飞沫挡板托架配件中不包含防飞沫挡板。

1. 在设备的一端将两个安装钩插入设备外壳的端槽中。
2. 将安装托架放在安装钩的顶端，螺丝孔对齐。
3. 使用随附的螺丝，将安装托架固定在设备末端附近。
4. 将托脚放置在安装托架的顶部并拧紧。

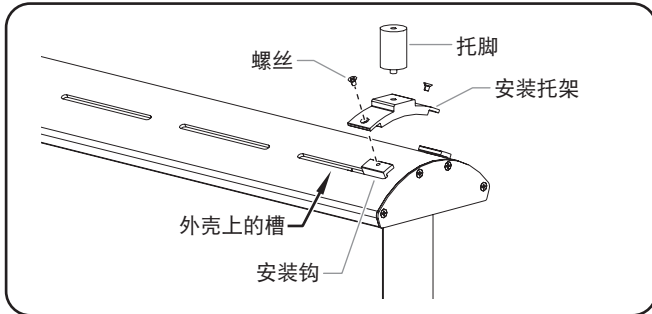

固定安装托架

5. 在设备的另一端安装另一个安装托架配件。
6. 确认托架的安装距离合适，与防飞沫挡板的孔对齐。
7. 在每个托脚顶部放置一个垫圈。
8. 将防飞沫挡板（未提供）放在托脚顶部，孔对齐。
9. 在防飞沫挡板顶部的每个孔上放置一个垫圈。
10. 使用指旋螺丝将防飞沫挡板固定到设备上。

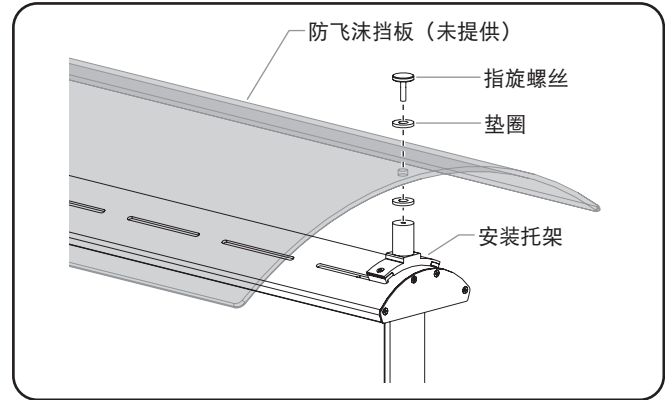

固定防飞沫挡板

保证，唯一补救措施：

Hatco 公司（卖方）保证其制造的产品（产品）在正常使用条件下和严格按照工厂建议进行储存、维护和安装时，不存在材料和工艺缺陷。根据本保证，卖方对直接向卖方购买产品的个人或实体（客户）的唯一义务是在以下期限内由卖方或卖方授权的服务机构（由卖方决定）维修或更换经卖方检查认为有缺陷的任何产品或任何部件：(i) 从卖方发货起的保修期内或 (ii) 根据卖方书面说明注册产品之日起的保修期内，以二者中较晚者为准。“保修期”应指十八 (18) 个月的期限，或下面针对具体产品组件规定的期限。经卖方事先书面许可退回的产品或部件的退款将按照卖方材料退回授权表上的条款执行。未经卖方事先书面许可退回的产品或部件将不予退款。卖方不会赔偿客户因退回、更换或移除产品产生的费用。如果缺陷符合有限保证条款，则将维修或更换产品并返还给客户，卖方将负责支付返还产品的运费。本文规定的维修或更换补救措施是客户的唯一补救措施。客户或他人的任何不当使用、改装、维修、篡改、误用、不当安装、施加不当电压或任何其他作为或不作为（包括任何未经授权服务机构的使用），如果经卖方自行判断会给产品带来不利影响，则会使本保证无效。本文明确规定的保证只能由客户主张，不能由客户的客户或产品的其他用户主张；但是，如果客户是卖方的授权设备经销商，则客户可以将本文的保证转让给客户的客户，但要遵守这些条款的所有限制，这种情况下，保证应由卖方根据这些条款完全控制。该有限保证是唯一保证，并取代任何其他明示或暗示的保证，包括但不限于任何暗示的不侵权、适销性、适于特定用途的保证，这些保证均被明确否认。

两 (2) 年部件保证：

履带烤面包机元件（金属外壳）
 抽屉式保温柜元件（金属外壳）
 抽屉式保温柜抽屉滚轮和滑道
 食品保温柜元件（金属外壳）
 展示保温柜元件（金属外壳空气加热）
 储存保温柜元件（金属外壳空气加热）
 加热槽元件 — HW、HWB 和 HWBI 系列（金属外壳）
 电磁炉
 电磁保温柜

五 (5) 年部件保证：

3CS 和 FR 水箱

十 (10) 年部件保证：

电增压加热水箱
 燃气增压加热水箱

九十 (90) 天仅部件保证：

更换件

尽管本文有相反条款，但本文的有限保证不涵盖卖方自行决定的组件，例如但不限于以下组件：涂层的白炽灯泡、荧光灯、加热灯泡、涂层的卤素灯泡、卤素加热灯泡、氙气灯泡、LED 灯泡、玻璃组件和保险丝；因石灰、沉积物堆积、化学侵蚀或冰冻造成的产品增压水箱、鳍管热交换器或其他水加热设备故障。

保修登记说明：

产品注册必须在我们工厂发货之日起 90 天内提交才能有资格享受附加保修覆盖。可通过卖方网站上的表格提交注册、通过产品上的二维码（如有）访问表格提交注册或通过致电客户服务并提供所需信息提交注册：**+1-414-671-6350**。

责任限制：

卖方不对任何间接、偶然、相应而生、惩罚性、惩戒性或特殊损失负责，包括但不限于由于产品被纳入或成为另一个产品的组件，或由于基于保修（明示或暗示）或基于合同、侵权或任何其他责任理论的任何其他原因而产生的任何利润损失、替换产品的费用或因出售、使用或安装产品而产生的人工费用，无论卖方是否已就产品的出售、使用或安装提出任何建议或陈述，即使卖方已知道此类损失的可能性。在任何情况下，卖方因本协议而产生的或与本协议相关的责任总额均不得超过客户在引起客户索赔的事件发生前三 (3) 个月内针对该产品向卖方支付的总额。即使本条款规定的有限补救的基本目的无效，本文规定的有关卖方责任的限制也应有效并强制执行。

卖方保留随时自行决定更新本条款的权利，更新自发布之日起生效。如需我们完整销售条款的最新版本，请访问我们的网站：<https://www.hatcocorp.com/terms-of-sale>

服务事项

此款 Hatco 设备的保修期为自购买之日起 1 年内或 Hatco 发货之日起 18 个月内，以先发生的日期为准。

如果此设备在保修期内出现问题，请做以下事项：

联系当地 Hatco 经销商

在联系 Hatco 经销商寻求服务帮助时，请为经销商提供以下信息，以确保及时处理：

- 设备型号
- 序列号（位于设备）
- 设备具体问题
- 购买日期
- 商业名称
- 邮寄地址
- 联系人姓名和电话号码

Hatco 经销商会做以下事项：

- 按需提供更换零部件
- 向 Hatco 提交保修索赔以供处理

非保修问题

如果遇到需要帮助的非保修问题，请联系最近的 Hatco 授权服务代理。

查找最近的服务代理：

- 向 Hatco 致电：(0512) 6732-5091
- 向 Hatco 发送电子邮件：infocn@hatcocorp.com

GB Symbol Identification

CN 符号标识



Safety Alert
安全警示



Read Operator's Manual
阅读操作手册



Caution — Hot Surface
小心 — 高温表面



Power ON
电源打开



Power OFF
电源关闭



Standby
待机



Protective Earth Ground
保护性接地



Earth Ground
接地



Equipotential Ground
等电位接地



Alternating Current
交流电



Phase
相位



Water Fill, Low Water
注水, 水位低



Humidity, Humidity Cycle
湿度, 湿度循环

**HATCO CORP. FOODSERVICE
EQUIPMENT (SUZHOU) CO. LTD.**
Unit A/No. 9 Weixin Road
Suzhou Industrial Park, Jiangsu, China
Telephone (0512) 6732-5091
info@hatcocorp.com
www.hatcocorp.com